

SERIES 5 DELIVERY SYSTEM

Technical Specification

DCI **EDGE**

SWING MOUNT

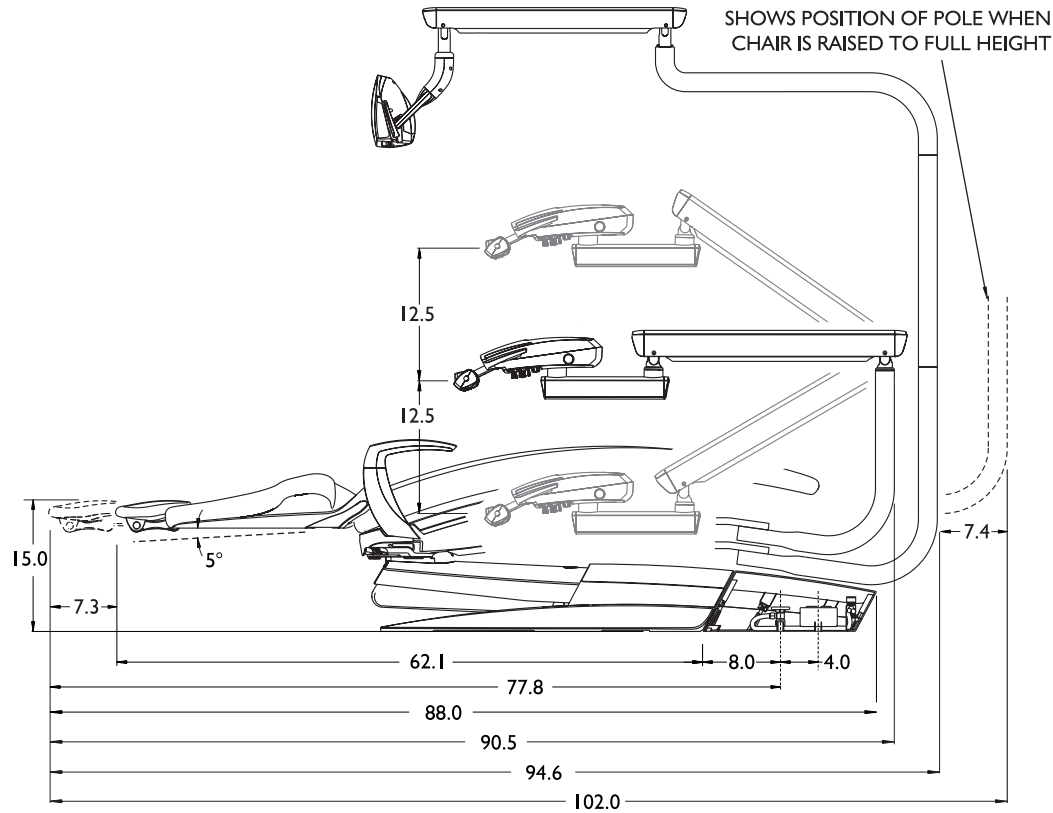

POWER REQUIREMENTS: 100-240VAC .6A 50-60Hz

AIR

Air Quality: Dry and clean

Pressure: 80-105 psi

WATER

Water Quality: Potable

Hardness: 7.2 - 7.8 pH

Pressure: 40-80 psi

IEC MEDICAL CLASSIFICATION 2A

TYPE: BF Power optics

Splash Protection: IPX0

CERTIFICATIONS: IEC 60601-1 3rd Edition,
CAN/CSA C22.2 No. 601.1

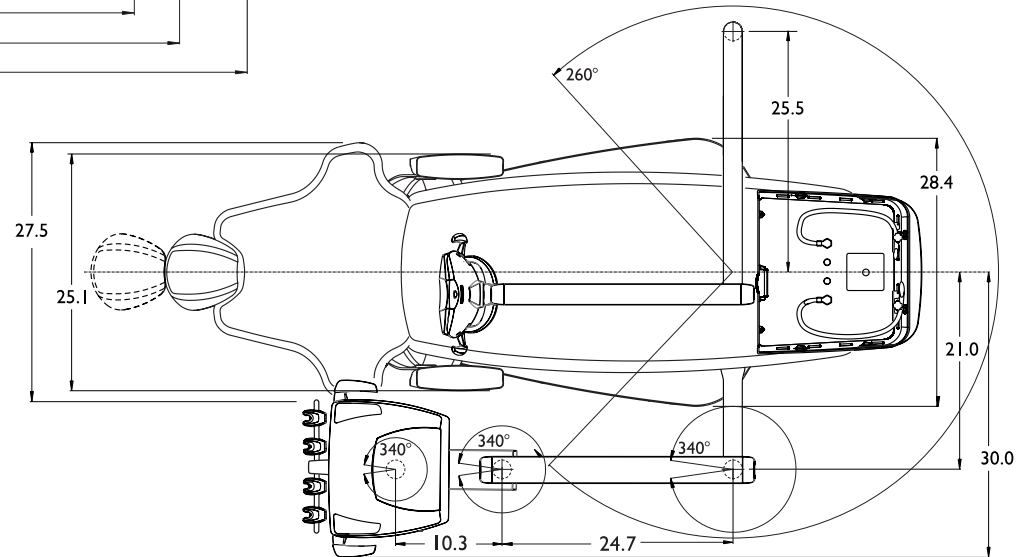

PMU MOUNT

