

SERIES 5 SIDE DENTAL DELIVERY SYSTEM

OVERVIEW

SIDE DENTAL DELIVERY SYSTEM
DW5050 / DW5550

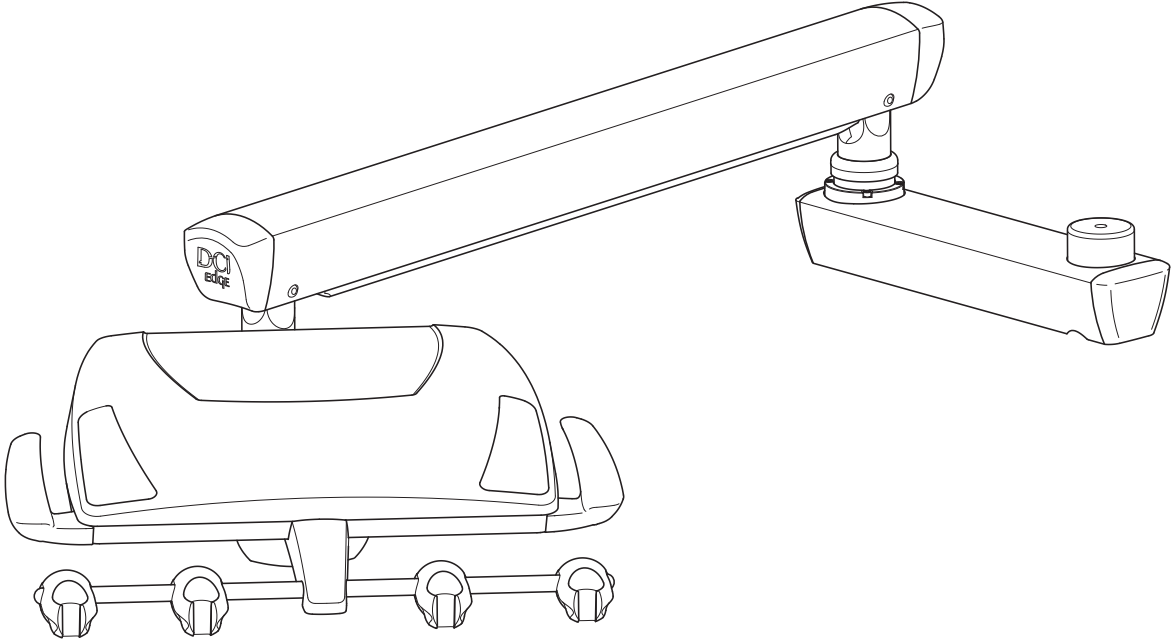

INTRODUCTION

SYMBOLS

The following symbols may be used throughout this product manual:



























-  **CAUTION:** Failure to carefully follow the described procedure may result in damage to the equipment.
-  **WARNING:** Failure to carefully follow the described procedure may result in damage to the equipment, the operator, and/or the operator.
-  **ELECTRICAL HAZARD:** Risk of electrical shock present. Ensure that power is disconnected before attempting this procedure.
-  **NOTE:** Take note of additional important information. Not a warning or caution.
-  Manufacturer
-  Manufacturing date
-  Type BF applied part
-  Waste Electrical and Electronic Equipment
-  Class I ME Equipment
-  Alternating Current (AC)
-  **CE** Conforms to applicable European Directives (Essential Requirements)
-  **ETL** Electrical Testing Lab
-  Advisable to consult accompanying documents
-  Chair Function: Directional movement
-  Chair Function: Chair preset position keys 0 and 1
-  Program key
-  Chair Function: Return to last position key
-  Light Function: Light ON/OFF toggle
-  Air Flow Control
-  Cup Fill
-  Water Flow Control
-  Bowl Rinse
-  Scaler Control
-  Master On/Off
-  Micro Motor Control
-  Flush

TABLE OF CONTENTS

Overview	2
Introduction	3
General Information	4
General Safety	5
Operation - Series 5 Keypads	6
Operation - Control Head	7
Operation - Utilities	8
Operation - Self-Contained Water System	9
Adjustments	10
Maintenance	14
Electromagnetic Compatibility	21

GENERAL INFORMATION

INTENDED APPLICATION AND USE

The dental delivery system is a device intended to support the instruments used by the dental practitioner, delivering those instruments to an accessible position during a dental procedure. This device may control and be the means of delivering compressed air, water, vacuum and low voltage electricity to a variety of instruments commonly used in dental practice.

PRODUCT IDENTIFICATION

This device can be identified by the label on the underside of the dental delivery system head. This label states the model number, serial number, electrical specifications, manufacturing date, software version, and safety classifications. Note the **sample** label at right.



APPLICABLE MODEL

DW5

ELECTRICAL SPECIFICATIONS

100-240VAC .6 Amps 50-60Hz	IEC Medical Classification I TYPE: BF Power optics Splash Protection: IPX0
----------------------------------	--

ACCESSORY DEVICES:

Power Optics:

Operation: Intermittent
Duty cycle: 20 sec ON, 10 sec OFF, 10X/hr

ELECTRICAL DEVICE INTERFERENCE

To guarantee the operational safety of electromedical devices, it is recommended that the operation of mobile radio telephones in the medical practice or hospital be prohibited. Strong EMI sources such as electro-surgery dental delivery systems or x-ray dental delivery systems may affect performance. If performance problems occur, move the dental delivery system to another electrical circuit or physical location.

TECHNICAL DOCUMENTATION

The manufacturer will make available upon request circuit diagrams, component part lists, descriptions, and calibration instructions to technical personnel responsible for the installation and service of this equipment.

PREVENTATIVE INSPECTION

The performance of the equipment can be affected by use over time. Periodically inspect the water and air lines for visible cracks or cuts and inspect for loose fittings and fasteners which could lead to leaks or other poor performance characteristics. Inspect joints and tensioning screws as a regular maintenance item to ensure proper positioning of the device.

AIR AND WATER SUPPLY

AIR Air Quality: Dry and clean Pressure: 80-105 psi	WATER Water Quality: Potable Hardness: 7.2 - 7.8 pH Pressure: 40-80 psi
--	---

ENVIRONMENTAL CONDITIONS

Operating Conditions:
Temperature: 67-76° F
Humidity: 20-60%

Shipping conditions:
Temperature: -68 - 122° F
Humidity: 10-90%

PRODUCT DISPOSAL

Contact your local, authorized dealer for disposal of this device to ensure compliance with your local environmental regulations.

GENERAL SAFETY

WARNINGS & CAUTIONS



WARNING: This product must be disinfected before use.



CAUTION: Only authorized service technicians should attempt to service this equipment. Use of other than authorized technicians will void the warranty.



CAUTION: Use a licensed electrician for all wiring.



WARNING: Modification of this equipment is not allowed.



WARNING: Failure to disinfect this device between patients could expose the user and patient to cross contamination and bioburden/biocontamination.



WARNING: Power cords and their associated parts cannot be substituted without increase risk of shock or fire. Use authorized replacement parts only. Power cords must be installed by qualified personnel. Ensure all service loops, strain reliefs and cord guards are in place and that line and neutral wires are secured.



WARNING: Failure to return handpieces to their proper locations could result in alternate or additional handpieces operating without notice.



WARNING: Proper personal protective equipment (PPE) including but not limited to gloves and eye protection must be used when cleaning debris trap.



WARNING: Do not allow children unsupervised access to the dental delivery system and auxiliary equipment.









NOTE: This product is intended for use by trained dental/medical professionals only.



WARNING: To isolate from mains power, unplug the cord. Make sure to leave the mains cord accessible.

OPERATION - SERIES 5 KEYPADS

NORMAL OPERATION

Unit Keypad Function List			
Key	Description	Initiate Function	Cancel Function
	LIGHT ON/OFF: Turns light on and off. Long press of light button will activate and cancel "No cure" function of the light.	Press key	Press key
	RETURN TO LAST POSITION: Returns chair to the previous position (last position held for longer than 10 seconds).	Press key to initiate function	Press any key to cancel function
0 1	PRESET POSITIONS: Activates preset positions programmed into the chair.		
  Backrest Incline Chair Up   Backrest Recline Chair Down	BACKREST INCLINE: Raises the backrest. BACKREST RECLINE: Lowers the backrest. CHAIR UP: Raises the seat of the chair. CHAIR DOWN: Lowers the seat of the chair.	Press key to initiate function	Release key to cancel function

DENTAL DELIVERY SYSTEM KEYPAD

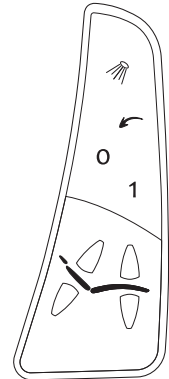

SETTING PRESET POSITIONS

ASSIGN POSITION TO "0" OR "1"

1. Adjust the position of the chair that you want to assign to a Preset Position key.
2. Press and hold "0" or "1" for five seconds. A long audible beep will sound to indicate that the assignment is complete.

*** Only lights which are electrically connected to a DCI Edge patient chair may be operated utilizing this key on the Series 5 keypads.**

OPERATION - CONTROL HEAD

CONTROLS

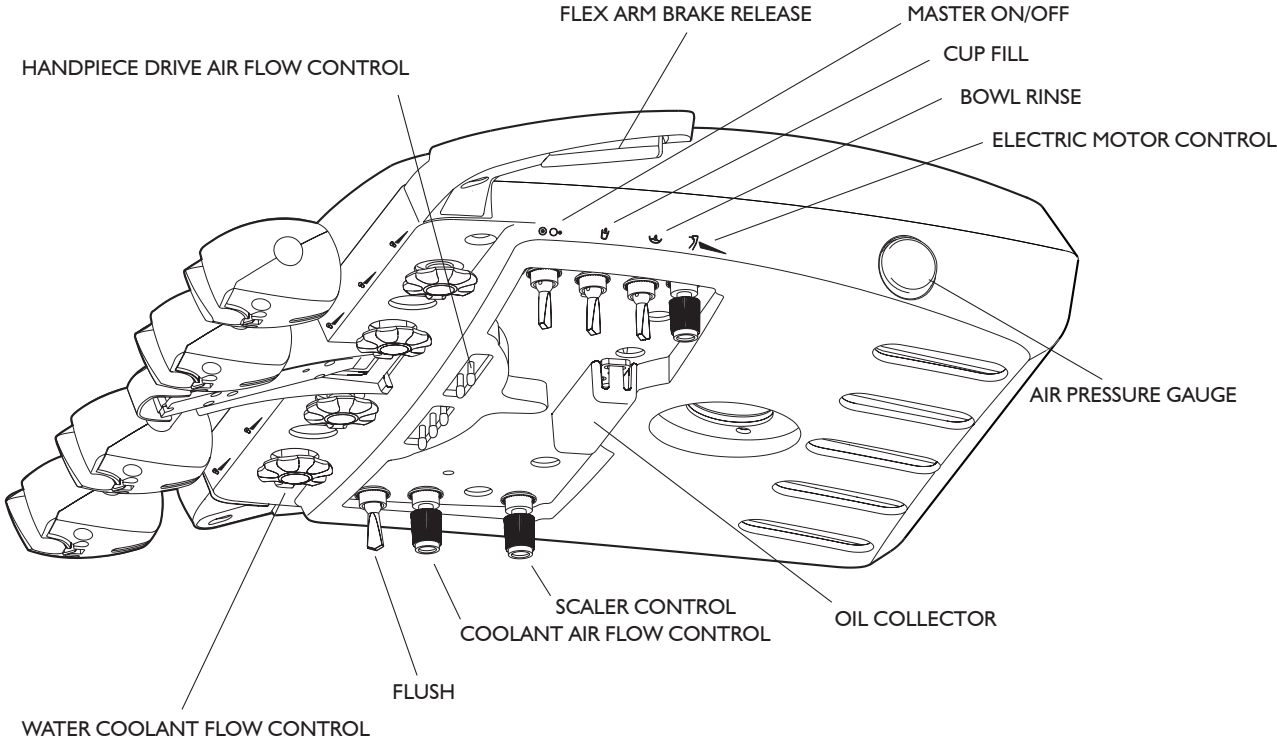

OPERATION - UTILITIES

CONTROLS

CONTROL HEAD: All of the operating controls are located on the underside of the control head where they are sheltered from most airborne contaminants.

MASTER ON/OFF: Located on the left side of the control head towards the front, this toggle switch activates the air and water shut-off valves, which control the air and water supplies to the dental delivery system.



CAUTION: When not in use, **ALWAYS** turn the Master On/Off switch to the Off position. The master switch is an important safety device that must be utilized in order to prevent accidental flooding.

FLUSH: Located on the left side of the control head to the rear of the Master On/Off, this momentary toggle is used to purge the coolant water from the handpiece tubing. Hold the handpiece tubing over a suitable container, then activate and hold the toggle for at least 30 seconds to flush out the handpieces.

AIR BRAKE: Located in the left and right handles the control head towards the front, these momentary toggles activate and release the pneumatic brake in the flex arm.

AIR COOLANT/CHIP AIR FLOW CONTROL: Located on the left side of the control head, this master control valve adjusts the amount of air coolant flow to all of the handpieces. Rotate counterclockwise to increase flow, clockwise to decrease flow.

HANDPIECE FLOW CONTROLS: Located at the front of the control head, these individual control valves adjust the amount of water coolant supplied to its corresponding handpiece. Rotating the control valve counterclockwise increases water coolant, rotating the control valve clockwise decreases water coolant.

HANDPIECE HOLDERS: Handpiece selection is automatic. The handpiece auto-holders contain actuator valves that activate each handpiece when lifted from its holder, without the need for manual selection.

FOOT CONTROL

DRIVE AIR CONTROL: Dental delivery systems are equipped with wet-dry, variable speed, disc type foot controls. Foot pressure on any part of the foot control disc controls the flow of air to the active handpiece.

WATER COOLANT ON/OFF: This toggle interrupts the flow of water coolant to the handpieces when performing a procedure that requires dry cutting.

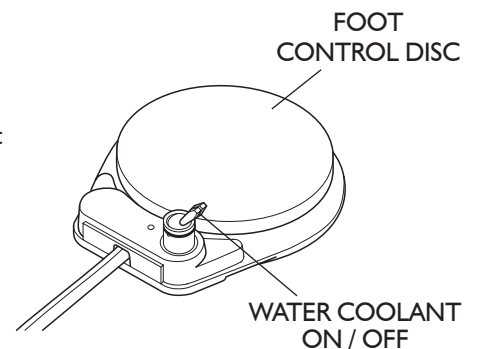

OPERATION - SELF-CONTAINED WATER SYSTEM

USING BOTTLED WATER

SELF-CONTAINED WATER SYSTEM

The self-contained water system allows you to isolate your practice from the municipal water supply. The self-contained water system uses a pressurized bottle to supply water to the dental delivery system, giving you full control of the source and quality of the water. A selector valve allows you to select either the city water supply or a bottled water supply of your own choice.

USING WATER BOTTLE

1. Ensure that the Water Bottle On/Off switch is turned OFF. Fill the water bottle to just below the neck, then install to the manifold. Turn the Water Bottle On/Off switch to the ON position and check for leakage at the bottle. If air or water leakage is observed, turn the Water Bottle On/Off switch OFF to release all pressure before tightening the bottle to stop leakage.
2. Select either city water or bottled water supply source, as desired, using the City/Bottle Selector on the dental delivery system.

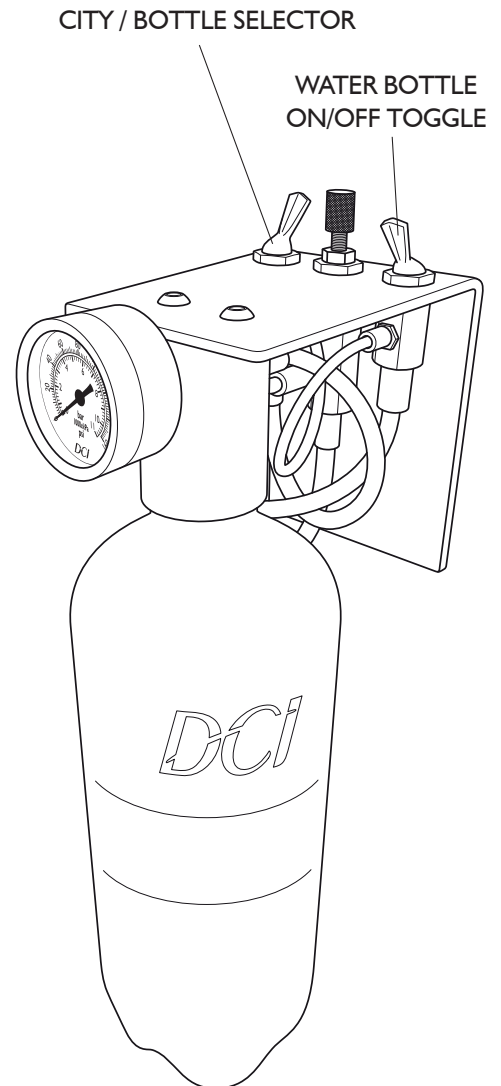

REFILLING THE BOTTLE

1. Turn the Water Bottle On/Off switch to the OFF position and allow several seconds for air pressure to be released from the bottle. **Never attempt to unscrew the bottle while it is pressurized!**
2. After relieving pressure, remove the empty bottle and install a full bottle.
3. Turn the Water Bottle On/Off to the ON position and check for leakage at the bottle as previously described.



CAUTION: Only use water bottles supplied by the manufacturer. Do not use soft drink bottles which are thin walled and may rupture when under pressure.



WARNING: Do not attempt to adjust the water bottle pressure. Bottle pressure is factory pre-set at 40 psi. Pressurizing the water bottle over 40 psi may cause the bottle to rupture.

ADJUSTMENTS

UTILITY CENTER

The Utility Center comes factory preset at 40 psi for Water pressure and 80 psi for Air pressure. All regulator adjustments should be made with the Master On/Off in the ON position.

1. **TO INCREASE AIR AND/OR WATER PRESSURE:** Turn the knob clockwise to the desired pressure.
2. **TO DECREASE AIR AND/OR WATER PRESSURE:** Turn the knob counterclockwise to the desired pressure.

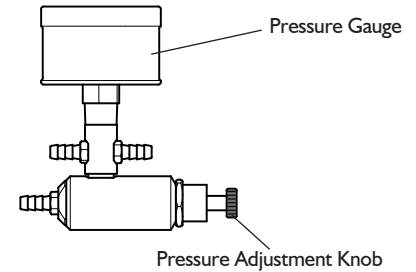

NOTE: When decreasing pressure, pressure must be relieved from the system. This may be achieved by pressing the syringe buttons to attain an accurate measurement from the gauges.

DRIVE AIR

1. Identify the adjustment knobs for controlling drive air on the underside of the control head as shown (right).
2. Install a bur in the handpiece that is to be adjusted. The drive air adjustment screws on the handpiece block correspond with the handpiece positions on the holder bar.
3. Run the handpiece. With the foot control plate fully depressed, turn the corresponding adjustment screw. Clockwise to decrease pressure, counterclockwise to increase pressure.

DRIVE AIR FLOW ADJUSTMENT

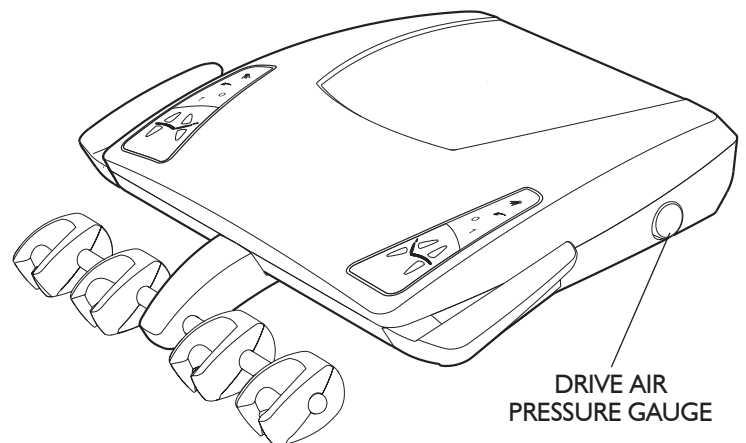
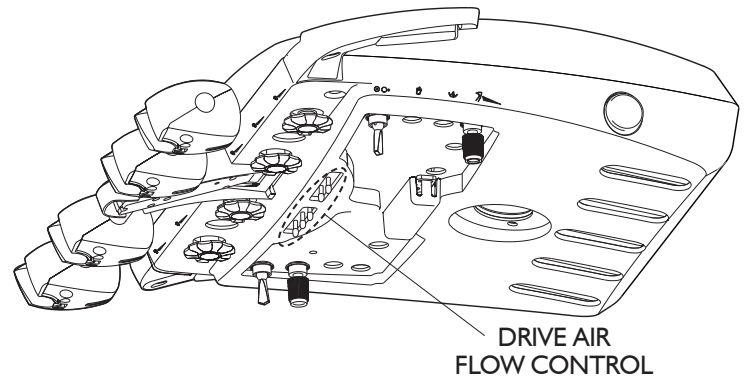

ADJUSTMENTS

DOCTOR'S SYRINGE

Adjusting screws allow you to control the flow of air and water from the syringe to prevent splashing and to achieve a desirable mist pattern. The adjusting screws are located under the dental delivery system head directly below the syringe control block.

1. Use a 3/32" hex key or the ball driver provided with the dental delivery system to make the syringe flow adjustment. Identify which adjusting screw is for air and which is for water by the color of the tubing connected to the block. Blue is water, yellow is air.
2. Adjust the water first, with the syringe button fully depressed. Turn the screw clockwise to decrease flow or counterclockwise to increase flow.
3. After adjusting the water to the desired flow, press both buttons simultaneously and adjust the air flow to achieve a mist pattern that suits your needs.

SYRINGE CONTROL BLOCK

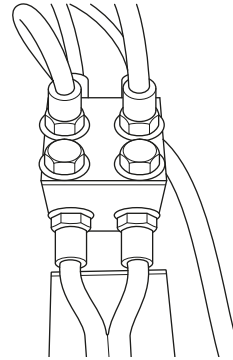

ADJUSTMENT SCREWS

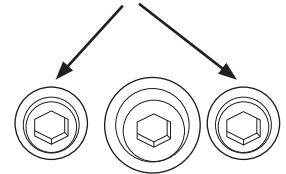

REAR FLEX ARM AND RIGID ARM ROTATION

The rotational tension of the flex arm may be adjusted at the set screw on the post, with a 3/32" hex key, located below the joint where the rear knuckle of the flex arm joins the rigid arm. Similarly the rotational tension of the rigid arm can be adjusted via the set screw on the opposite end of the rigid arm.

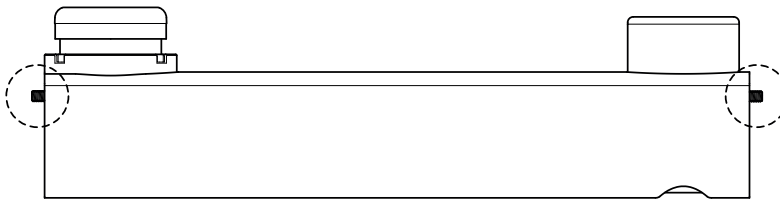

SET SCREWS

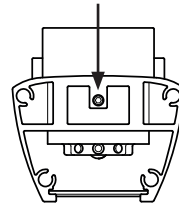

HOLDER

The handpiece holders come pre-spaced and leveled from the factory, but may be re-positioned for the user's needs.

1. With a 1/8" hex key, loosen the two set screws located on the bottom of the holder.
2. Reposition the holder in the desired location.
3. Retighten the two set screws with the 1/8" hex key to secure the holder in position.

SET SCREWS

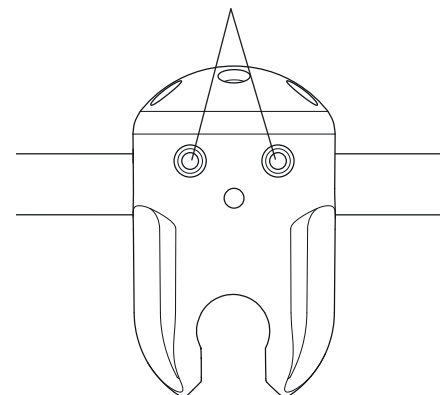

ADJUSTMENTS

FLEX ARM TENSIONING

The Flex Arm is preset at the factory, however it may be necessary to re-adjust tension to the user's needs. After adjusting the spring tension, the dental delivery system head must be leveled (see head leveling).

1. Turn off master switch and wait for air to fully bleed off.
2. Loosen set screw (for 5-6 full turns) in the stop block located above and behind the front knuckle (A).
3. Proceed to instructions below for increase or decrease of tension.

TO INCREASE SPRING TENSION

1. Remove the end cap at the front of the flex arm and loosen the set screw in the knuckle block which is located above and behind the front knuckle adjustment screw using a 3/32" hex key (A).
2. Remove the end cap at the rear of the flex arm and increase the spring tension by rotating the **adjustment screw in the rear knuckle clockwise** with a 3/16" hex key (B). Retighten the knuckle block set screw (A). Replace the end caps.

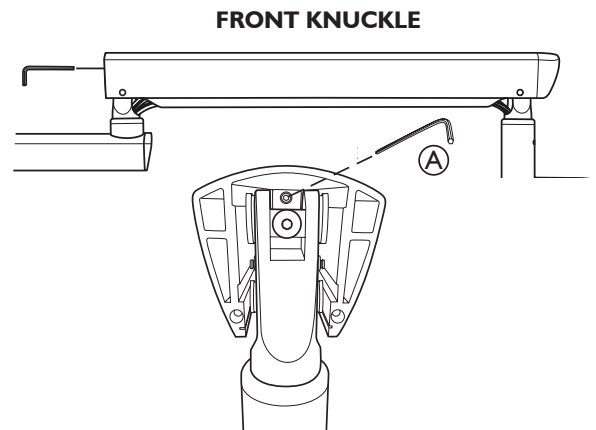

TO DECREASE SPRING TENSION

1. Remove the end cap at the front of the flex arm and loosen the set screw in the knuckle block which is located above and behind the front knuckle adjustment screw using a 3/32" hex key (A).
2. Decrease the spring tension by rotating the **adjustment screw in the front knuckle clockwise** with a 3/16" hex key. Retighten the stop block set screw. Replace the end cap (A).

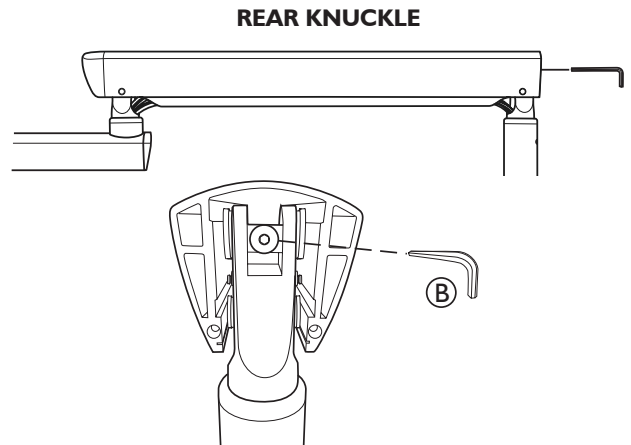

WARNING: Do not attempt to decrease spring tension by rotating the **adjustment screw in the rear knuckle counterclockwise**. This might thread the screw out of the control rod causing the dental delivery system to drop suddenly, damaging the equipment and the operator.

ADJUSTMENTS

HEAD LEVELING

Leveling of the control head will be necessary when the dental delivery system is first installed and any time that the flex arm spring tension has been adjusted.

1. Turn off master switch and wait for air to fully bleed off.
2. Loosen set screw (for 5-6 full turns) in the stop block located above and behind the front knuckle (A).
3. Place the delivery system head inline with the flex arm in the approximate working position for the doctor.
4. Place a level on the short rigid arm in front of the knuckle.
5. Adjust the dental delivery system head angle by turning the adjustment screw in the front knuckle (B).
6. When the dental delivery system head is level, retighten the set screw in the stop block to secure the adjustment (A).

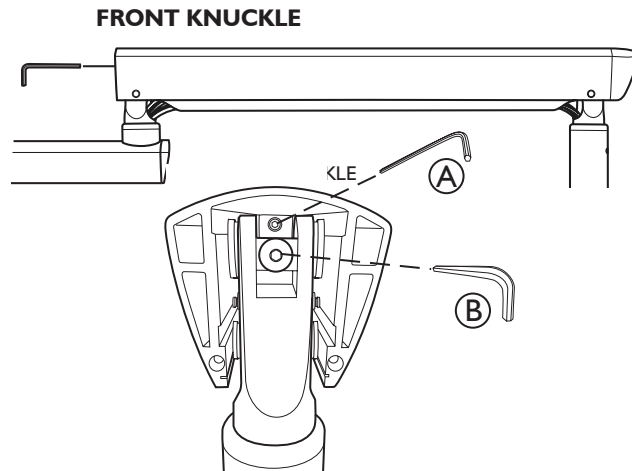

FRONT FLEX ARM AND HEAD ROTATION

Rotational tension is preset at the factory, however it may be necessary to increase or decrease tension to suit the user's needs.

FOR FRONT FLEX ARM ROTATION

1. Remove the rear end cap from the short rigid arm.
2. Using a 3/32" hex key, increase swivel tension by turning the set screw clockwise or decrease by turning counterclockwise.

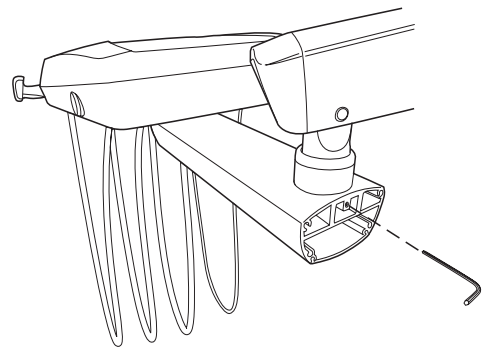

FOR HEAD ROTATION

1. Remove the front end cap from the short rigid arm.
2. Using a 3/32" hex key, increase swivel tension by turning the set screw clockwise or decrease by turning counterclockwise.

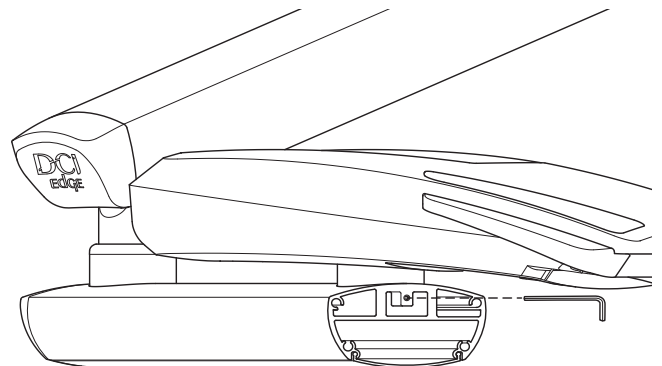

MAINTENANCE

BARRIER TECHNIQUE

Wherever possible, use disposable barriers and change them between patients. The barrier technique will ensure maximum long term durability of the surfaces and finishes of the equipment.

CLEANING

Dental equipment, categorized as noncritical devices with low risk of infection transmission, come into contact only with intact skin. Before applying disinfectant, clean the surfaces with a mild detergent and a clean cloth to remove unwanted dirt and debris

CHEMICAL DISINFECTION

Follow the instructions below carefully to ensure the longest life for your equipment:

1. Only use the acceptable disinfectants listed. Use of unacceptable products may void your warranty.
2. When applying chemicals with a spray bottle, **do not spray surfaces directly**. Instead, spray a cloth and then wipe the surfaces with the wet cloth.
3. When using chemical disinfectants, always pay strict attention to the manufacturer's disinfectant directions.
4. When using concentrated disinfectants, measure the concentrate carefully and mix according to package directions. **Disinfectant solutions at higher than recommended dilution ratios are extremely corrosive.**
5. Thoroughly wash all areas that have been exposed to disinfectant cleaners with mild soap and warm water at least once per day. This wash down will minimize the harmful effects of chemical disinfectant residues being allowed to accumulate on the equipment.

STERILIZATION

Among the various sterilization methods available, it is vital to remember that temperatures must not surpass 275°F (135°C) regardless of your chosen approach.

The recommended sterilization method is Steam Autoclave.

1. To prepare the instruments, begin by cleaning them under running water for 30 seconds using a soft brush.
2. Subsequently, place the instruments in an ultrasonic bath with an enzymatic cleaner to thoroughly remove superficial debris.
3. This step is crucial to enhance the overall effectiveness of the sterilization process.
4. For wrapped instruments, ensure that the parameters are set at 132°C (270°F) for 15 minutes, with an additional 30-minute drying time, especially when utilizing a gravity displacement autoclave.
5. For unwrapped instruments, the recommended parameters are 132°C (270°F) for 3 minutes, maintaining a temperature-controlled environment within a gravity displacement autoclave.



CAUTION: Do not use powdered cleansers, scouring pads or abrasive scrubbers on any of the painted, plastic or metal surfaces of this dental delivery system. To remove dried-on material, use a soft bristled brush and a solution of mild detergent.

Conditionally Acceptable Disinfectants

- Phthalaldehyde
- Quarternary Ammonium
- Glutaraldehyde



CAUTION: These disinfectants will harm the surface finish of dental equipment and are not recommended.

Unacceptable:

- Strong Phenols/Phenol Alcohol combinations
- Sodium Hypochlorite/Household Bleach
- Sodium Bromide
- Strong Alcohol
- Household Cleaners (Dental Equipment Only)
- Citric Acids
- Iodophors
- Ammonium Chloride
- Accelerated Hydrogen (0.5%)

MAINTENANCE

DENTAL DELIVERY SYSTEM WATERLINES

Dental delivery system waterlines are susceptible to contamination by various microorganisms, including slime-producing bacteria, fungi, and protozoans. These contaminants colonize the inner surfaces of waterline tubing, giving rise to biofilms – complex microbial accumulations.

Biofilms: Biofilms are prevalent in natural environments, thriving wherever there is moisture and a suitable surface for attachment.

Source of Contamination: Water entering dental facilities from city supplies or wells carries non-sterile waterborne bacteria and trace nutrients. This creates an environment conducive to bacterial attachment and biofilm development within waterlines.

Amplification and Reservoir: Biofilms serve as a reservoir, substantially increasing the concentration of microorganisms in the water exiting the dental delivery system waterlines. The amplified microbial load includes clinically significant pathogens such as *Pseudomonas*, *Legionella*, and non-tuberculosis *Mycobacterium* species.

Water Quality Standards: Water used for dental procedures should meet nationally recognized microbial standards. The maximum permissible limit for heterotrophic, mesophilic water bacteria is set at 500 CFU/mL, consistent with drinking water standards.

Caution with Water Heating: While heating water has been practiced for patient comfort, it's important to note that warming water can inadvertently promote biofilm formation and the growth of organisms adapted to human hosts. Caution should be exercised when considering water heating practices.

Waterlines Maintenance Schedule: Recent advancements in infection prevention for dental delivery system waterlines have highlighted the significance of a well-structured waterline maintenance protocol. The following three fundamental steps are integral to an effective waterline maintenance approach:

Monitoring Water Quality: To ensure the maintenance of water quality, regular monitoring should be conducted using appropriate monitoring kits. Follow the instructions provided by the manufacturer for accurate usage of the monitoring kits. Regular monitoring will enable timely identification of any deviations from the desired water quality standards, allowing for prompt corrective measures to be taken.

Shocking Treatment: Should the results indicate elevated levels of microbial contamination or other deviations from desired standards, use a shock treatment to bring your water back into compliance. This procedure involves the application of a potent disinfectant, to thoroughly eliminate contaminants. This treatment eradicates major buildup, ensuring a fresh start for the waterlines. Shocking is a pivotal step in preparing your new dental equipment waterlines for first time use.

Routine Treatment: Following the initial shocking process, sustained cleanliness is maintained through the use of treatment products. These products effectively reduce and hinder the re-growth of bacteria, sustaining the sanitized conditions achieved through shocking.

Disinfectants for the Dental Delivery System Waterlines

For effective disinfection of dental delivery system waterlines, the use of disinfectants containing chlorhexidine or iodophor has shown the best results. These disinfectants have demonstrated high efficacy in eliminating microbial contamination and maintaining waterline cleanliness.

The following commercially available products are suggested for waterline treatment:

DentaPure™ — Microbiological Dental Delivery System Water Purification System – Iodine-based cartridge system by Crosstex

Liquid Ultra™ — A hydrogen peroxide based, two part liquid solution by Crosstex

It is important to follow the instructions provided by the manufacturers for proper usage of these products to ensure optimal results in maintaining waterline cleanliness.

MAINTENANCE



WARNING: During the product evaluation carried out by the American Dental Association (ADA), Chlorox™ Regular Bleach, sodium hypochlorite, showed favorable results. However, it is important to note that scientific literature has indicated the potential toxicity of this substance to individuals.



WARNING: Due to its corrosive nature, sodium hypochlorite can pose a risk to users' skin and mucous membranes upon contact. Therefore, careful consideration is advised when contemplating the utilization of this product for dental delivery system waterline treatment. Furthermore, it should be noted that apart from its potential toxicity to patients, sodium hypochlorite can also cause damage to internal components of the dental delivery system. Consequently, the use of bleach solutions should be avoided.

DENTAL DELIVERY SYSTEM WATERLINE DISINFECTION PROCESS

To ensure effective disinfection of dental delivery system waterlines, the process should involve the use of a combination of distilled water and a suitable disinfectant. Be sure to follow the manufacturers instructions.

1. Start by filling the water reservoir of the dental delivery system.
2. Add the recommended amount of the chosen disinfectant to the water in the reservoir. Follow the manufacturer's instructions for the correct dosage to achieve the desired disinfection efficacy.
3. Remove all handpieces (including slow speed handpieces) and any accessories connected to handpiece tubings.
4. Activate the water system and allow the mixture of water and disinfectant to flow through the waterlines for the recommended duration specified by the disinfectant manufacturer. Ensure that the water flows through all water-bearing lines, including quick-disconnect lines and other relevant components. This ensures that the disinfectant reaches all parts of the waterlines, effectively eliminating microbial contamination.
5. After the recommended contact time, thoroughly flush the waterlines with clean distilled water to remove any residual disinfectant solution.

DAILY PURGING OF WATER-BEARING LINES

To ensure a clean and uncontaminated water supply, it is crucial to perform daily purging of all water-bearing lines at the beginning of each workday. This process involves thorough flushing of the waterlines for a minimum duration of two (2) minutes. The purging should encompass all relevant lines, including handpiece and syringe lines, quick-disconnect lines, and any other applicable lines.

Follow these steps for effective daily purging:

1. Activate the water system and open all handpiece and syringe flow valves to allow water flow through the lines.
2. Flush the waterlines with water for a minimum duration of two (2) minutes. Ensure that the water flows through all water-bearing lines, including quick-disconnect lines and other relevant components.
3. Pay careful attention to each line to ensure thorough flushing and removal of any stagnant water or debris.
4. After purging, remove the bottle and set upside down on a counter.

MAINTENANCE

PURGING AIR AND WATERLINES AFTER EACH PATIENT

To maintain cleanliness and prevent cross-contamination, it is essential to perform purging of air and waterlines after every patient. This protocol ensures the removal of any residual fluids or contaminants from the lines. The purging process should include both air and waterlines and should be carried out for a minimum duration of 20 seconds.

Follow these steps for proper purging after each patient:

1. After completing the dental procedure, ensure that all handpieces and other devices connected to the air and waterlines are turned off.
2. Leave all handpieces and devices that had been used during last procedure in place.
3. Activate the air and water systems to allow the flow of air and water through the lines.
4. Purge the air and waterlines for a minimum duration of 20 seconds. This helps flush out any remaining fluids, debris, or potential contaminants from the lines.
5. Monitor the purging process to ensure adequate flow and complete removal of any residual substances.
6. After purging remove all used handpieces and accessories for cleaning and sterilization.



WARNING: In order to mitigate the risk of cross-contamination between patients, disinfection and sterilization of handpieces must occur after each dental procedure. Refer to the handpiece manufacturer's instructions and recommendations for sterilization or disinfection procedure.

ASSISTANT'S VACUUM INSTRUMENTS

AFTER EACH PATIENT: Draw clear water through each valve, while opening and closing it several times. Leave the valve open for several seconds to allow all of the water to clear the hoses. The HVE and Saliva Ejector tips should always be replaced with sterile ones before each patient.

END OF EACH DAY: We recommend that you draw a vacuum system sanitizing solution through each valve, while opening and closing it. EcoVac is an effective vacuum system cleaner that is non-toxic and environmentally safe.

MAINTENANCE

DISINFECTING THE BOTTLE

Fill bottle with the 100 ml disinfectant solution, shake vigorously and let it settle for 10 minutes. Shake again, then rinse twice with water.



CAUTION: Disinfect new water bottle prior to first use.

It is recommended that 100 ml of disinfectant solution is mixed for each weekly bottle disinfecting procedure. Always use a fresh mixture every week.

The Disinfectant Solution:

- 9 parts (90 ml) Tap water
- 1 part (10 ml) 5.25% Sodium hypochlorite (household bleach)

HANDPIECE OIL COLLECTOR

The oil collector is located on the bottom surface of the control head chassis at the back left. Replace the 2" x 2" gauze pads with clean pads in the handpiece oil collector at least every 90 days, or more often if handpieces are oiled frequently. Remove the oil collector by pulling downward.

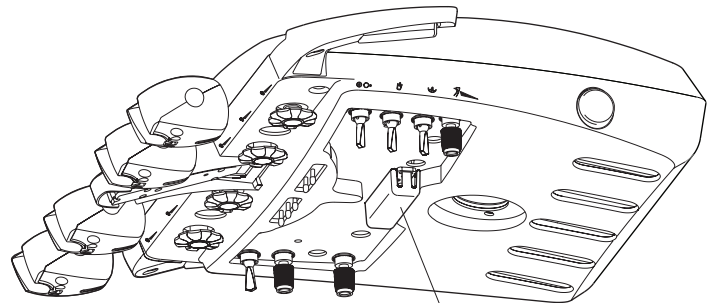

OIL COLLECTOR

SOLIDS COLLECTOR

Turn off the vacuum pump. Remove the solids collector cap and lift out and dispose of the screen. If you find an excessive amount of material in the screen, more frequent cleaning is necessary.

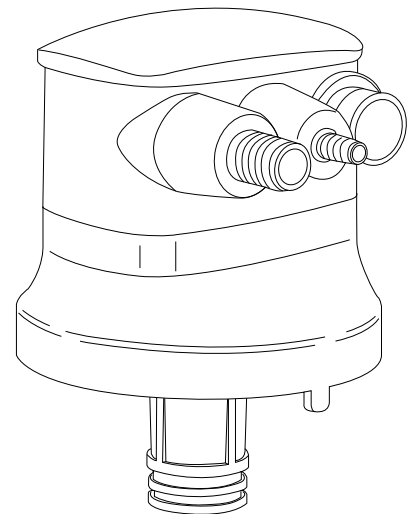

MAINTENANCE

PRE-PROCEDURAL MOUTHWASH

To promote a reduction in bacterial count and enhance infection control measures, the use of a mouthwash containing either 0.01% chlorhexidine or essential oils is recommended immediately prior to a dental procedure. This step has shown to be effective in minimizing bacterial presence.

Follow this protocol for pre-procedural mouthwash administration:

1. Prior to the dental procedure, provide the patient with a suitable mouthwash solution containing either 0.01% chlorhexidine or essential oils.
2. Instruct the patient to rinse their mouth with the mouthwash for a duration of 60 seconds.
3. Ensure that the patient swishes the mouthwash thoroughly around the oral cavity, reaching all areas, including the teeth, gums, and tongue.
4. After 60 seconds, instruct the patient to spit out the mouthwash and avoid swallowing it.

HANDPIECE FLUSH - DAILY MAINTENANCE

The dental delivery system is equipped with a handpiece flush system that allows you to periodically flush fresh water through the handpiece tubings. The need for this is caused by the low flow of water through the tubings during normal use, which can lead to stagnation and the potential growth of “biofilm” contamination.

It is recommended that you flush the tubings at the beginning and end of each day. This may be done with or without the handpieces installed, but having the handpieces on the tubings will restrict flow, so a longer flush time will be required. All of the tubings are flushed simultaneously. Hold them together and direct them into a basin, sink or cuspidor to catch the water. Flip and hold the flush toggle.

Allow adequate time for fresh water to make its way through the entire system and displace all standing water. The American Dental Association and the Centers for Disease Control can provide additional recommendations regarding this procedure, including information on frequency and duration of flushing and the use of antibacterial solutions in the self-contained water system.



WARNING: In order to mitigate the risk of cross-contamination between patients, disinfection and sterilization of handpieces **must occur after each dental procedure**. Refer to the handpiece manufacturer’s instructions and recommendations for sterilization or disinfection procedure.

MAINTENANCE

DENTAL DELIVERY SYSTEM - WEEKLY MAINTENANCE

A cleaning procedure should be performed at least once a week, preferably at the start of the week before treating patients. If the dental delivery system is to be stored for any length of time, perform a weekly maintenance routine immediately before and after storage.

1. Purge the dental delivery system with air.
2. Flush the system with disinfectant solution:
 - a. Turn the dental delivery system Master switch to the Off position. Empty the water bottle, replacing the water with cleaning solution.
 - b. Hold the handpiece tubing and syringe over the cuspidor or other suitable container. Turn the dental delivery system on, wait a few moments, then operate the flush toggle, syringe and foot control until a continuous stream of cleaning solution is running through the system.
3. Allow the disinfectant to remain in the dental delivery system for 10 to 20 minutes, then flush the system again until all the cleaning solution is used up.
4. Purge the dental delivery system with air:
 - a. Hold the handpiece tubing and syringe over a container. Turn the Master Switch to the On position, wait a few moments, then operate the flush toggle, syringe and foot control until all cleaning solution is purged from the system.
 - b. Turn the dental delivery system Master Switch to the Off position. (If the dental delivery system will be stored, stop here.)
5. Fill with clean water:
 - a. With the dental delivery system Master Switch turned to the Off position, remove the empty disinfectant bottle. Replace with clean bottle and clean water.
 - b. Hold the handpiece tubing over a suitable container. Turn the dental delivery system on, wait a few moments, then operate the flush toggle until a continuous stream of water is flowing through the system. Replace handpieces and do the same with the syringe. The dental delivery system is now ready for use.

ELECTROMAGNETIC COMPATIBILITY

DEVICE COMPATIBILITY

ELECTRICAL MEDICAL

Electrical medical devices are subject to special EMC safety measurements and as a result the equipment must be installed according to the installation instruction manual.

PORTABLE ELECTRONIC DEVICES

Portable and mobile high frequency electronic communications equipment may interfere with electronic medical devices.

STATIC SENSITIVE DEVICES

Where labeled this equipment contains static sensitive devices that require special precautions when handling. At a minimum a grounded wrist strap that is connected to a ground stud should be worn to reduce the possibility of damage.

ACCESSORY USE

Using accessory devices not specified by DCI for use with their equipment may result in an increase of electromagnetic emissions and/or a decrease in electromagnetic immunity of the system.

INTERFERENCE FROM OTHER EQUIPMENT

If other equipment is used adjacent to or stacked with the DCI Edge equipment, the system must be observed to verify normal operation.

DCI EDGE EQUIPMENT COMPLIANCE

This equipment has been tested and found to comply with the limits for medical devices in IEC 60601-1-2. These limits are designed to provide reasonable protection against harmful interference in a typical medical installation. In the event of interference, power the devices from separate main supplies and/or increase the physical distance between devices. Contact Customer Service if you have any questions.

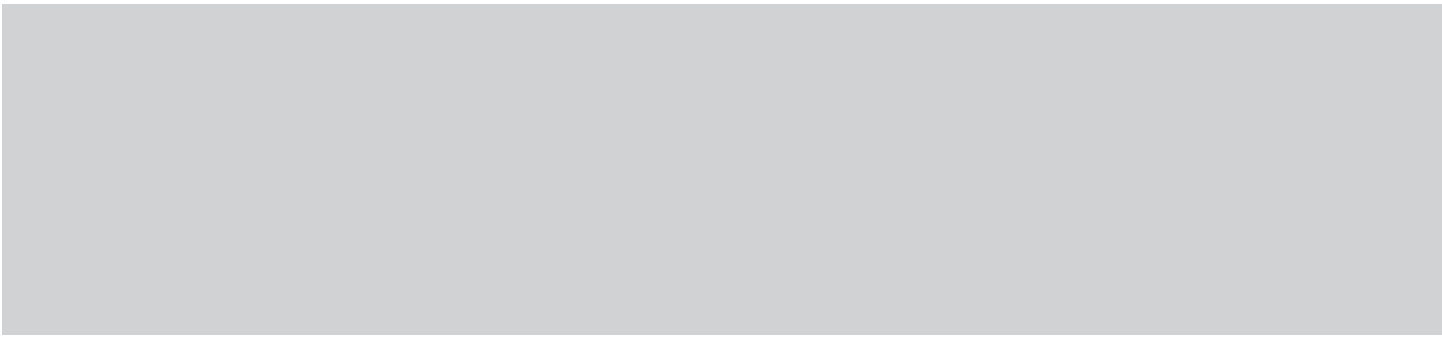

PN 50196, Rev. E, 2024-04-29

www.dcionline.com
800-624-2793



DCI International, LLC
705 S. Springbrook Road Bldg C
Newberg, OR 97132, USA