

SERIES 4 DENTAL DELIVERY SYSTEM

OVERVIEW

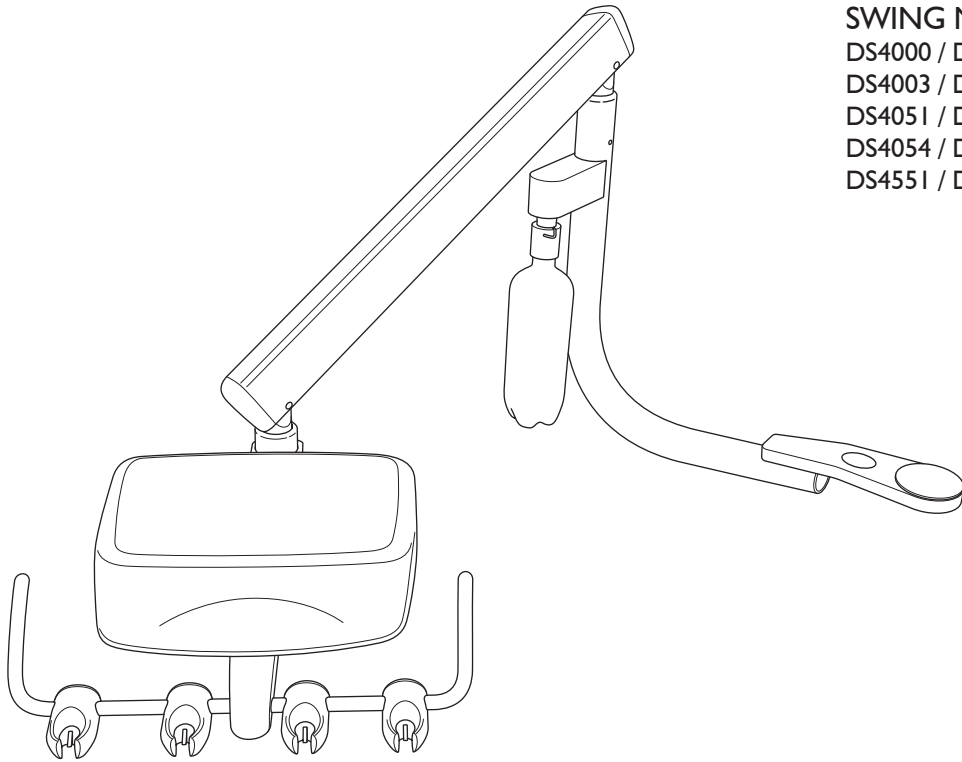

SWING MOUNT DELIVERY

DS4000 / DS4001 / DS4002 /
DS4003 / DS4004 / DS4050 /
DS4051 / DS4052 / DS4053 /
DS4054 / DS4100 / DS4550 /
DS4551 / DS4552

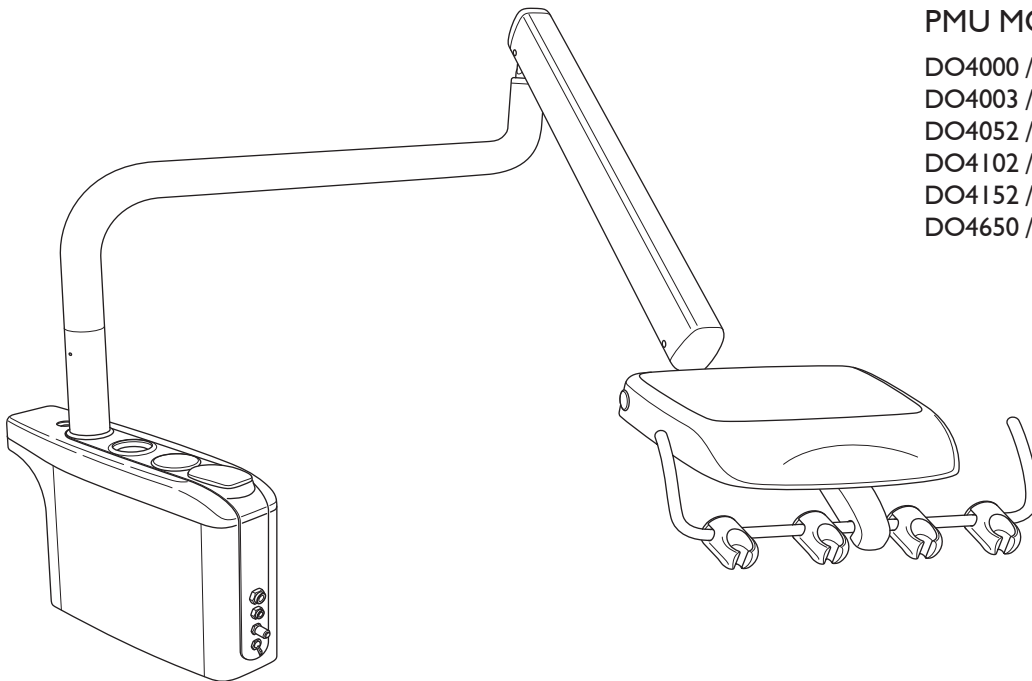

PMU MOUNT DELIVERY

DO4000 / DO4001 / DO4003 /
DO4003 / DO4050 / DO4051 /
DO4052 / DO4053 / DO4100 /
DO4102 / DO4103 / DO4150 /
DO4152 / DO4153 / DO4550 /
DO4650 / DO4652 /

INTRODUCTION

SYMBOLS

The following symbols may be used throughout this product manual:



WARNING: Failure to carefully follow the described procedure may result in damage to the equipment, the the operatory, and/or the operator.



CAUTION: Failure to carefully follow the described procedure may result in damage to the equipment.



NOTE: Take note of additional important information. Not a warning or caution.



ELECTRICAL HAZARD: Risk of electrical shock present. Ensure that power is disconnected before attempting procedure.



Manufacturer



Manufacturing date



Type BF applied part



Waste Electrical and Electronic Equipment



Protective Earth (ground)



Alternating Current (AC)



Conforms to applicable European Directives (Essential Requirements)



Electrical Testing Lab



Advisable to consult accompanying documents



Chair Function: Directional movement



Chair Function: Chair pre-set position keys 0 and 1



Light Function: Light ON/OFF toggle



Chair Function: Return to last position key



Air Flow Control



Cup Fill



Water Flow Control



Bowl Rinse



Scaler Control



Master On/Off



Micro Motor Control



Flush

TABLE OF CONTENTS

Overview	2
Introduction	3
General Information	4
General Safety	5
Operation - Series 4 Keypads	6
Operation - Control Head	7
Operation - Post Mount Utilities	8
Operation - Utilities	9
Operation-Self-Contained Water System	10
Adjustments	11
Disinfection and Sterilization	17
Maintenance	18
Electromagnetic Compatibility	21

GENERAL INFORMATION

INTENDED APPLICATION AND USE

The dental delivery system is a device intended to support the instruments used by the dental practitioner, delivering those instruments to an accessible position during a dental procedure. This device may control and be the means of delivering compressed air, water, vacuum and low voltage electricity to a variety of instruments commonly used in dental practice.

PRODUCT IDENTIFICATION

This device can be identified by the label on the underside of the dental delivery system head. This label states the model number, serial number, electrical specifications, manufacturing date, software version, and safety classifications. Note the **sample** label at right.



APPLICABLE MODEL

DO4, DS4

ELECTRICAL SPECIFICATIONS

100-240VAC	IEC Medical Classification I
.6 Amps	TYPE: BF Power optics
50-60Hz	Splash Protection: IPX0

ACCESSORY DEVICES:

Power Optics:

Operation: Intermittent
Duty cycle: 20 sec ON, 10 sec OFF, 10X/hr

ELECTRICAL DEVICE INTERFERENCE

To guarantee the operational safety of electromedical devices, it is recommended that the operation of mobile radio telephones in the medical practice or hospital be prohibited. Strong EMI sources such as electro-surgery dental delivery systems or x-ray dental delivery systems may effect performance. If performance problems occur, move the dental delivery system to another electrical circuit or physical location.

TECHNICAL DOCUMENTATION

The manufacturer will make available upon request circuit diagrams, component part lists, descriptions, and calibration instructions to technical personnel responsible for the installation and service of this equipment.

AIR AND WATER SUPPLY

AIR	WATER
Air Quality: Dry and clean	Water Quality: Potable
Pressure: 80-105 psi	Hardness: 7.2 - 7.8 pH
	Pressure: 40-80 psi

ENVIRONMENTAL CONDITIONS

Operating Conditions:
Temperature: 67-76° F
Humidity: 20-60%

Shipping conditions:
Temperature: -68 - 122° F
Humidity: 10-90%

PRODUCT DISPOSAL

Contact your local, authorized dealer for disposal of this device to ensure compliance with your local environmental regulations.

GENERAL SAFETY

WARNINGS & CAUTIONS



WARNING: This product must be disinfected before use.



CAUTION: Only authorized service technicians should attempt to service this equipment. Use of other than authorized technicians will void the warranty.



CAUTION: Use a licensed electrician for all wiring.



WARNING: Modification of this equipment is not allowed.



WARNING: Failure to disinfect this device between patients could expose the user and patient to cross contamination and bioburden/biocontamination.



WARNING: Power cords and their associated parts cannot be substituted without increased risk of shock or fire. Use authorized replacement parts only. Power cords must be installed by qualified personnel. Ensure all service loops, strain reliefs and cord guards are in place and that line, neutral and ground wires are secured.



WARNING: Failure to return handpieces to their proper locations could result in alternate or additional handpieces operating without notice.



WARNING: Proper personal protective equipment (PPE) including but not limited to gloves and eye protection must be used when cleaning debris trap.



WARNING: Do not allow children unsupervised access to the dental delivery system and auxiliary equipment.



NOTE: This product is intended for use by trained dental/medical professionals only.



WARNING: To isolate from mains power, unplug the cord. Make sure to leave the mains cord accessible.

OPERATION - SERIES 4 KEYPADS

NORMAL OPERATION

Keypads are located on the Left or Right sides of the Series 4 control head and rear mount assistant head.

LIGHT ON/OFF: Press this key to toggle the light ON or OFF.*

RETURN TO LAST POSITION: Press this key to return the chair to the previous position (last position held for longer than 10 seconds). Press any key to cancel while in motion.

PRESET POSITIONS: Press "0" or "1" to activate preset positions. Press any key to cancel while in motion.

BACKREST INCLINE: Press this key to raise the backrest.

BACKREST RECLINE: Press this key to recline the backrest.

CHAIR UP: Press this key to raise the seat of the chair.

CHAIR DOWN: Press this key to lower the seat of the chair.

SETTING PRESET POSITIONS

ASSIGN POSITION TO "0" OR "1"

1. Adjust the position of the chair that you want to assign to a Preset Position key.
2. Press and hold "0" or "1" for five seconds. A long audible beep will sound to indicate that the assignment is complete.

* Only lights which are electrically connected to a DCI Edge patient chair may be operated utilizing this key on the Series 4 keypads.

DENTAL DELIVERY SYSTEM KEYPAD

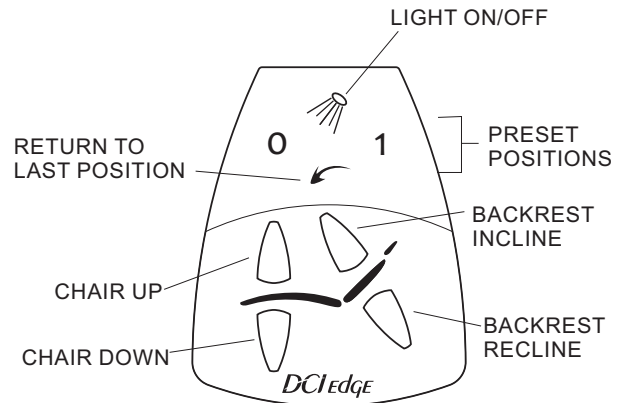

REAR ASSISTANT KEYPAD

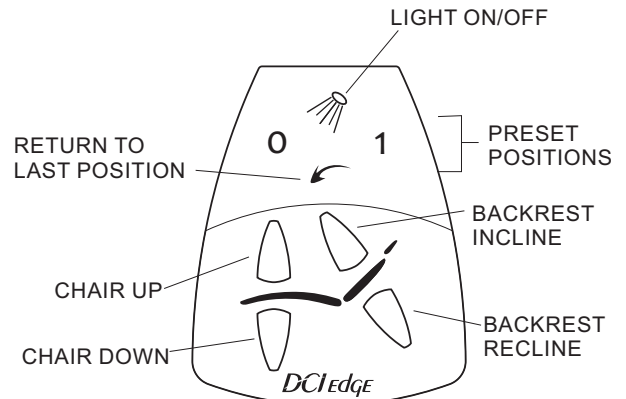

OPERATION - CONTROL HEAD

CONTROLS

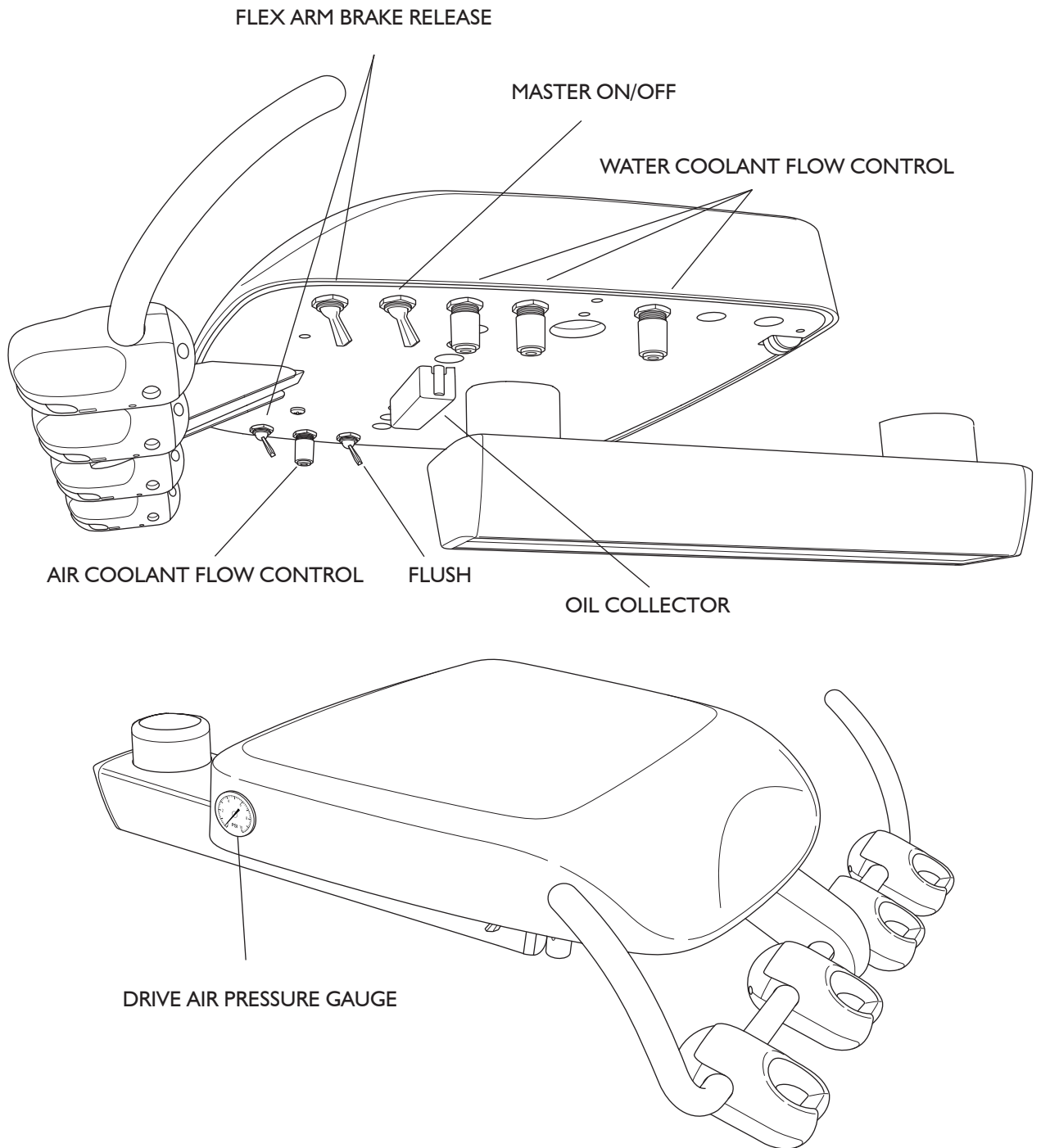

OPERATION - POST MOUNT UTILITIES

CONTROLS

CONTROL HEAD: All of the operating controls are located on the underside of the control head where they are sheltered from most airborne contaminants.

MASTER ON/OFF: Located on the right side of the control head towards the front, this toggle switch activates the air and water shut-off valves, which control the air and water supply to the dental delivery system.



CAUTION: When not in use, **ALWAYS** turn the Master On/Off switch to the Off position. The master switch is an important safety device that must be utilized in order to prevent accidental flooding.

FLUSH: Located on the left side of the control head to the rear of the Air Coolant Flow Control, this momentary toggle is used to purge the coolant water from the handpiece tubing. Hold the handpiece tubing over a suitable container, then activate and hold the toggle for at least 30 seconds to flush out the handpieces.

AIR BRAKE: Located on the left and right side of the control head towards the front, these momentary toggles activate and release the pneumatic brake in the flex arm.

AIR COOLANT FLOW CONTROL: Located on the left side of the control head, this master control valve adjusts the amount of air coolant flow to all of the handpieces. Rotate counterclockwise to increase flow, clockwise to decrease flow.

HANDPIECE FLOW CONTROLS: Located on the right side of the control head, these individual control valves adjust the amount of water coolant supplied to its corresponding handpiece. Rotating the control valve counterclockwise increases water coolant, rotating the control valve clockwise decreases water coolant.

HANDPIECE HOLDERS: Handpiece selection is automatic. The handpiece auto-holders contain actuator valves that activate each handpiece when lifted from its holder, without the need for manual selection.

OPERATION - UTILITIES

PMU CONTROLS

AIR QUICK CONNECT: This air output provides 80psi output to run accessories for the user. Accepts a 3/8" male quick connect fitting.

WATER QUICK CONNECT: This water output provides 40psi output to run accessories for the user. Accepts a 1/4" male quick connect fitting.

FLOW CONTROL: This needle valve adjusts the water output from the Water Quick Connect. Rotate counterclockwise to increase output and rotate clockwise to decrease output.

CITY / BOTTLE SELECTOR: This routing valve controls the water system input. With the toggle up in the "City" position, water enters the dental delivery system from the office plumbing. With the toggle down in the "Bottle" position, water enters the dental delivery system from the self-contained water system.

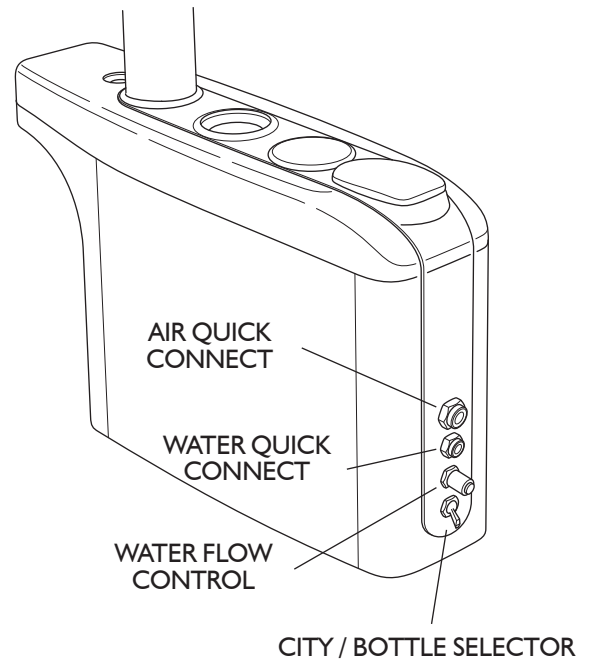

CUSPIDOR BUTTONS

CUP FILL: Place a cup below the spout and depress the cup fill button to fill the cup with water.

BOWL RINSE: Depress this button to start the flow of water to rinse out the cuspidor bowl.

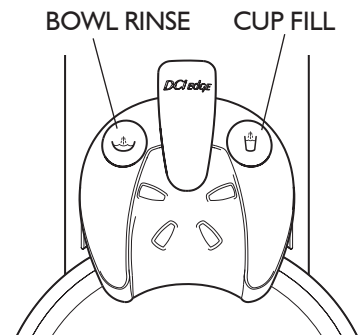

FOOT CONTROL

DRIVE AIR CONTROL: Dental delivery systems are equipped with wet-dry, variable speed, disc type foot controls. Foot pressure on any part of the foot control disc controls the flow of air to the active handpiece.

WATER COOLANT ON/OFF: This toggle interrupts the flow of water coolant to the handpieces when performing a procedure that requires dry cutting.

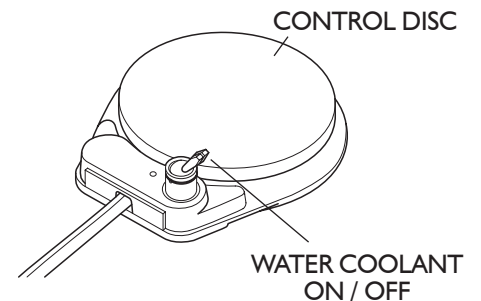

OPERATION - SELF-CONTAINED WATER SYSTEM

USING BOTTLED WATER

SELF-CONTAINED WATER SYSTEM

The self-contained water system allows you to isolate your practice from the municipal water supply. The self-contained water system uses a pressurized bottle to supply water to the dental delivery system, giving you full control of the source and quality of the water. A selector valve allows you to select either the city water supply or a bottled water supply of your own choice.

USING WATER BOTTLE

1. Ensure that the dental delivery system Master On/Off switch is turned OFF. Fill the water bottle to just below the neck, then install to the manifold. Turn the dental delivery system Master On/Off switch to the ON position and check for leakage at the bottle. If air or water leakage is observed, turn the dental delivery system Master On/Off switch OFF to release all pressure before tightening the bottle to stop leakage.
2. Select either city water or bottled water supply source, as desired, using the City/Bottle Selector on the dental delivery system.

REFILLING THE BOTTLE

1. Turn the dental delivery system Master On/Off switch to the OFF position and allow several seconds for air pressure to be released from the bottle. **Never attempt to unscrew the bottle while it is pressurized!**
2. After relieving pressure, remove the empty bottle and install a full bottle.
3. Turn the dental delivery system Master On/Off to the ON position and check for leakage at the bottle as previously described.



CAUTION: Only use water bottles supplied by the manufacturer. Do not use soft drink bottles which are thin walled and may rupture when under pressure.



WARNING: Do not attempt to adjust the water bottle pressure. Bottle pressure is factory pre-set at 40psi. Pressurizing the water bottle over 40psi may cause the bottle to rupture.

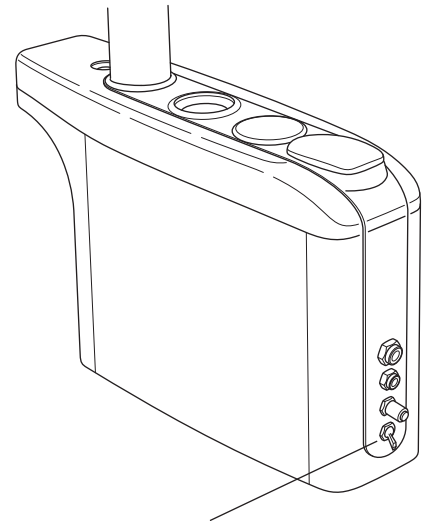

CITY / BOTTLE SELECTOR

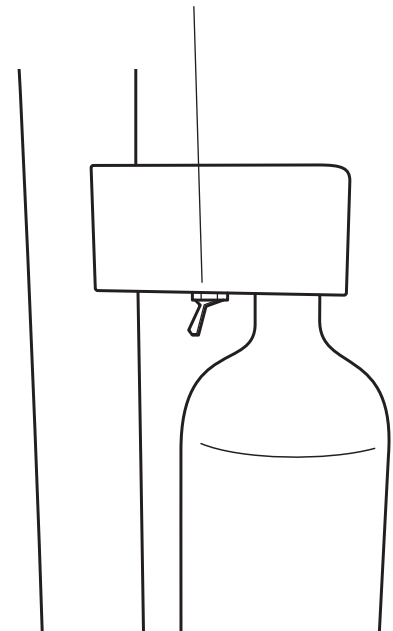

ADJUSTMENTS

UTILITY CENTER

Located in the J-Box, the Utility Center comes factory preset at 40psi for Water pressure and 80psi for Air pressure. All regulator adjustments should be made with the Master On/Off in the ON position.

1. **TO INCREASE AIR AND/OR WATER PRESSURE:** Turn the knob clockwise to the desired pressure.
2. **TO DECREASE AIR AND/OR WATER PRESSURE:** Turn the knob counterclockwise to the desired pressure.

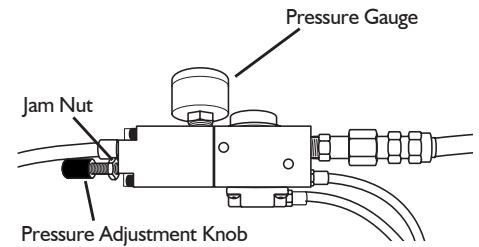

NOTE: When decreasing pressure, pressure must be relieved from the system. This may be achieved by pressing the syringe buttons to attain an accurate measurement from the gauges.

DRIVE AIR

1. Identify the adjustment knobs for controlling drive air on the underside of the control head as shown (right).
2. Install a bur in the handpiece that is to be adjusted. The drive air adjustment screws on the handpiece block correspond with the handpiece positions on the holder bar.
3. Run the handpiece. With the foot control plate fully depressed, turn the corresponding adjustment screw with a small slotted screwdriver. Clockwise to decrease pressure, counterclockwise to increase pressure.

DRIVE AIR ADJUSTMENT SCREWS

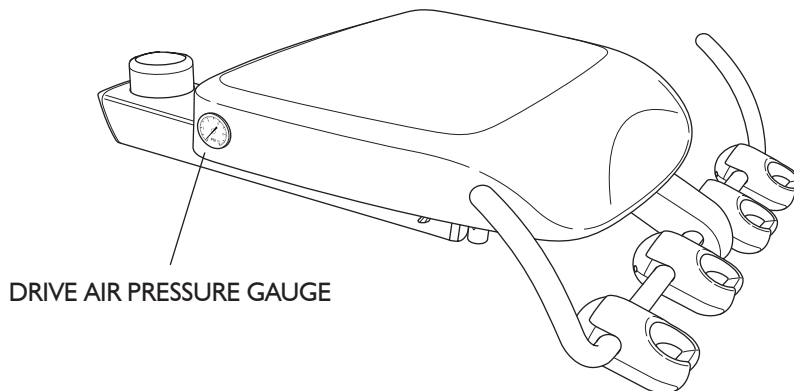
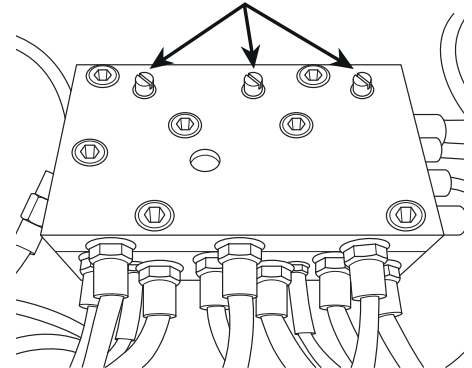

ADJUSTMENTS

DOCTOR'S SYRINGE

Adjusting screws allow you to control the flow of air and water from the syringe to prevent splashing and to achieve a desirable mist pattern. The adjusting screws are located under the dental delivery system head directly below the syringe control block.

1. Use a 3/32" hex key or the ball driver provided with the dental delivery system to make the syringe flow adjustment. Identify which adjusting screw is for air and which is for water by the color of the tubing connected to the block. Blue is water, yellow is air.
2. Adjust the water first, with the syringe button fully depressed. Turn the screw clockwise to decrease flow or counterclockwise to increase flow.
3. After adjusting the water to the desired flow, press both buttons simultaneously and adjust the air flow to achieve a mist pattern that suits your needs.

SYRINGE ADJUSTING SCREWS SYRINGE CONTROL BLOCK

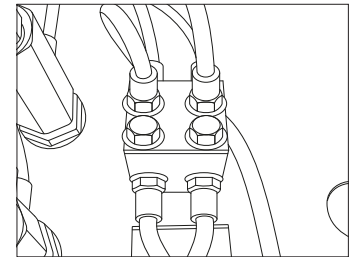
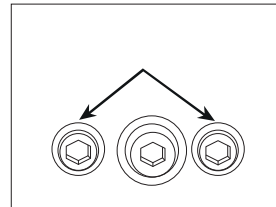

ASSISTANT'S SYRINGE

The Assistant's Syringe Block is located on the back wall inside of the PMU. Adjusting screws allow you to control the flow of air and water from the syringe to prevent splashing and to achieve a desirable mist pattern. Follow the steps above for the doctor's syringe block to adjust the assistant's syringe block.

ASSISTANT'S SYRINGE BLOCK

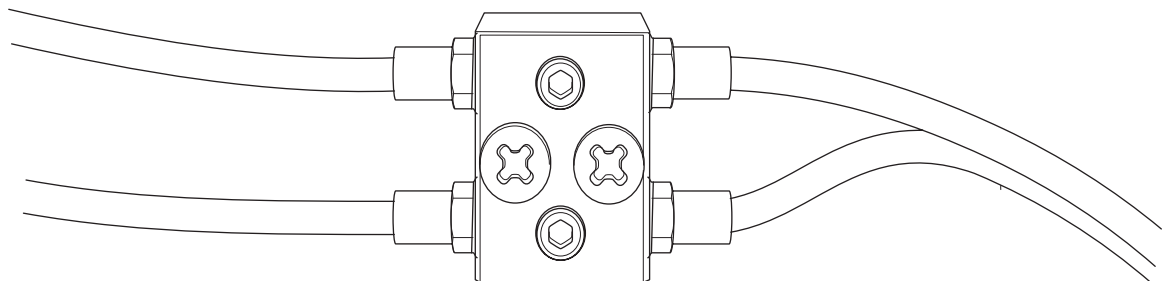

ADJUSTMENTS

FLEX ARM TENSIONING

The Flex Arm is preset at the factory, however it may be necessary to re-adjust tension to the user's needs. After adjusting the spring tension, the dental delivery system head must be leveled (see next page).

TO INCREASE SPRING TENSION

1. Remove the end cap at the front of the flex arm and loosen the set screw in the knuckle block which is located above and behind the front knuckle adjustment screw using a 3/32" hex key (A).
2. Remove the end cap at the rear of the flex arm and increase the spring tension by rotating the **adjustment screw in the rear knuckle clockwise** with a 3/16" hex key. Retighten the knuckle block set screw. Replace the end caps (B).

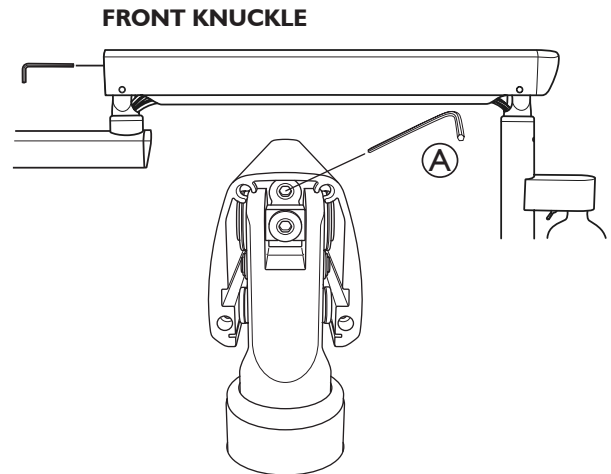

TO DECREASE SPRING TENSION

1. Remove the end cap at the front of the flex arm and loosen the set screw in the knuckle block which is located above and behind the front knuckle adjustment screw using a 3/32" hex key (A).
2. Decrease the spring tension by rotating the **adjustment screw in the front knuckle clockwise** with a 3/16" hex key. Retighten the stop block set screw. Replace the end cap (A).

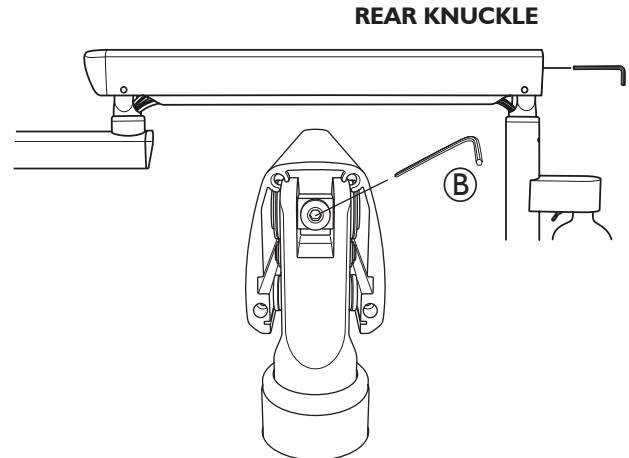

WARNING: Do not attempt to decrease spring tension by rotating the **adjustment screw in the rear knuckle counterclockwise**. This might thread the screw out of the control rod causing the dental delivery system to drop suddenly, damaging the equipment and the operator.

ADJUSTMENTS

HEAD LEVELING

Leveling of the control head will be necessary when the dental delivery system is first installed and any time that the flex arm spring tension has been adjusted. Before leveling, ensure that the swing arm assembly or the PMU post is level. For leveling of the swing arm assembly or the PMU post, refer to the installation instructions.

1. Loosen the set screw in the stop block located above and behind the front knuckle (A).
2. With the control in approximate working position for the doctor, use a small level to adjust the angle of the flex arm until it is level.
3. Place the level on the control head inline with the short rigid arm and the front knuckle.
4. Adjust the dental delivery system head angle by turning the adjustment screw in the front knuckle (B).
5. When the dental delivery system head is level, retighten the set screw in the stop block to secure the adjustment (A).

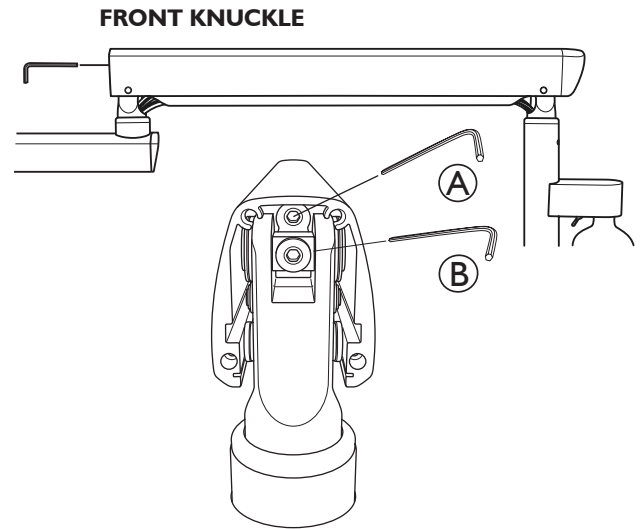

FRONT FLEX ARM ROTATION

Rotational tension is preset at the factory, however it may be necessary to increase or decrease tension to suit the user's needs.

1. Remove the rear end cap from the short rigid arm.
2. Using a 3/32" hex key, increase swivel tension by turning the set screw clockwise or decrease by turning counterclockwise.

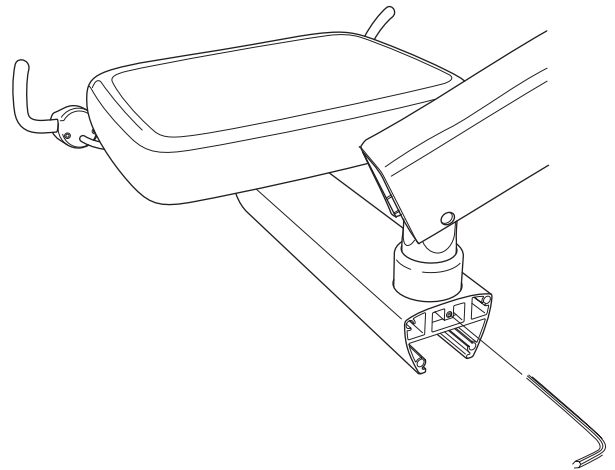

ADJUSTMENTS

REAR FLEX ARM ROTATION

The rotational tension of the flex arm may be adjusted at the set screw on the post, with a 3/32" hex key, located below the joint where the rear knuckle of the flex arm joins the rigid arm.

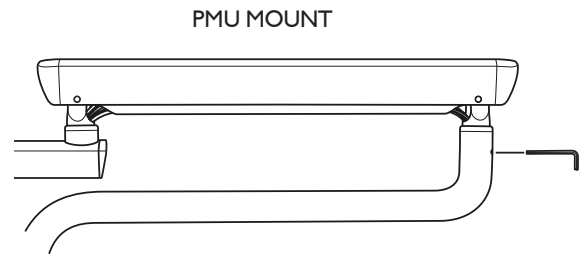
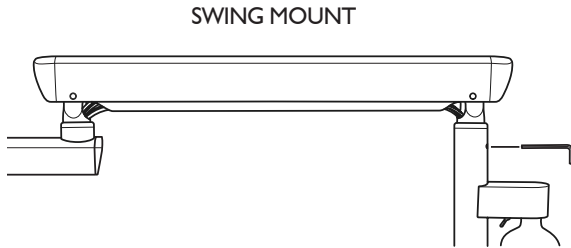

RIGID ARM ROTATION

PMU MOUNT DELIVERY ONLY
(NOT AVAILABLE FOR SWING MOUNT DELIVERY)

Access the tensioning set screw by removing the access panel on the side of the PMU. The set screw is located on the side of casting where the rigid arm is attached as shown.

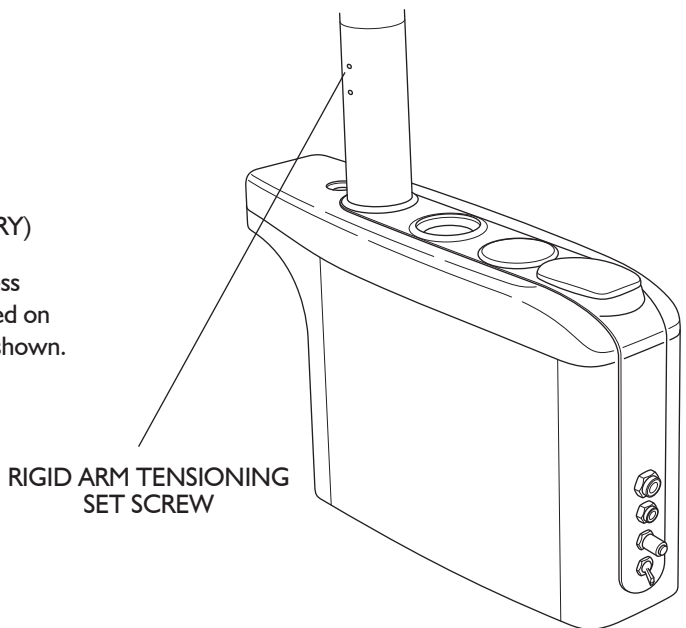

WARNING: Swing Arm axle bolts are factory set to 50 ft.lbs. of torque. Do not attempt to adjust these bolts as damage to the equipment and/or user may result.

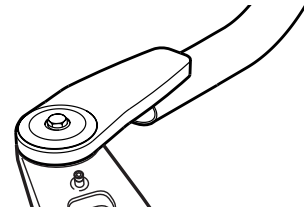

ADJUSTMENTS

TELESCOPING ARM

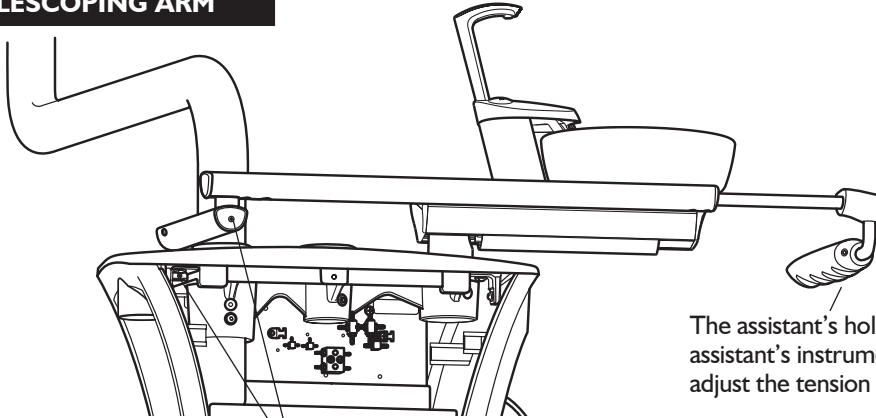

The tension on the pivot points for the telescoping arm can be adjusted. Using a 3/32" hex key, adjust the tension at the set screws (2) as indicated.

The assistant's holder pivots to provide tilt for the assistant's instruments. Using a 5/32" hex key, adjust the tension at the set screw indicated.

BOWL RINSE TIMING

The length of time that the bowl will rinse is controlled by a valve inside the cuspidor assembly.

1. Remove the bottom access cover and find the regulator and timing valve which is tucked to one side of the drain.
2. Adjust the timing screw on the valve (right) with a small, flat head screwdriver. Turning the screw clockwise shortens the rinse time, while turning it counterclockwise lengthens the time.

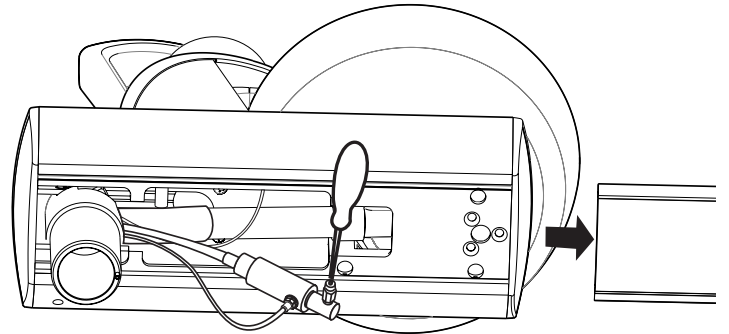

HOLDER

The handpiece holders come pre-spaced and leveled from the factory, but may be re-positioned for the user's needs.

1. With a 1/8" hex key, loosen the two set screws located on the bottom of the holder.
2. Reposition the holder in the desired location.
3. Retighten the two set screws with the 1/8" hex key to secure the holder in position.

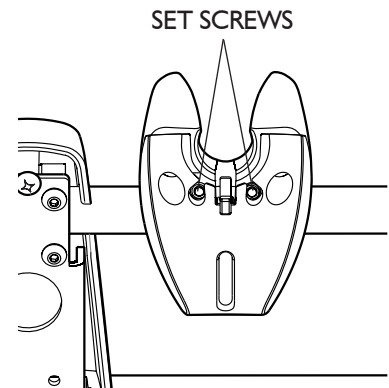

DISINFECTION AND STERILIZATION

BARRIER TECHNIQUE

Wherever possible, use disposable barriers and change them between patients. The barrier technique will ensure maximum long term durability of the surfaces and finishes of the equipment.

DISINFECTION & STERILIZATION

The Manufacturer will not attempt to specify the required intervals for disinfection nor can it recommend the overall best surface disinfectant. Please refer to the Infection Control Recommendations published by the American Dental Association for further information.

The use of chemical disinfecting agents is not necessary if the instrument is going to be sterilized. While their use may be easy and quick, it is important to know the effectiveness of any chemical disinfectant against the various agents of infection that may be encountered.

CHEMICAL DISINFECTION

Follow the instructions below carefully to ensure the longest life for your equipment:

1. Only use the acceptable disinfectants listed. Use of unacceptable products will void your warranty.
2. Thoroughly wash all areas that have been exposed to disinfectant cleaners with mild soap and warm water at least once per day. This wash down will minimize the harmful effects of chemical disinfectant residues being allowed to accumulate on the equipment.
3. When using chemical disinfectants, always pay strict attention to the manufacturer's disinfectant directions.
4. When using concentrated disinfectants, measure the concentrate carefully and mix according to package directions.
5. Disinfectant solutions that are relatively harmless to surfaces at their recommended strengths can be corrosive at higher than recommended dilution ratios.

Conditionally Acceptable Disinfectants

- Phthalaldehyde
- Quarternary Ammonium
- Glutaraldehyde



CAUTION: These disinfectants will harm the surface finish of dental equipment and are not recommended.

Unacceptable:

- Strong Phenols/Phenol Alcohol combinations
- Sodium Hypochlorite/Household Bleach
- Sodium Bromide
- Strong Alcohol
- Household Cleaners (Dental Equipment Only)
- Citric Acids
- Iodophors
- Ammonium Chloride
- Accelerated Hydrogen (0.5%)

STERILIZATION

There are several methods of sterilization that may be used. It is important to remember, however, that regardless of the method you choose, temperatures should never exceed 275° Fahrenheit (135° Celsius). Any of the following sterilization methods may be safely used on your autoclavable instruments:

- Steam Autoclave
- Ethylene Oxide Gas
- Chemical Vapor Process

Do not allow the instruments to come into contact with the walls of the sterilizer. Avoid placing the instruments in close proximity to the sterilizer heating element. Dry heat sterilization is not recommended because of the difficulty in maintaining the precise temperature control necessary to prevent damage to the instruments.



CAUTION: When using the chemical vapor process, it is essential to rinse out all cleaning agents with clear water.

The internal surfaces and passages must be thoroughly purged of residual cleaning agents by flushing with water then isopropyl alcohol. This will prevent the formation of a crystalline residue resulting from reactions between the chemical vapor solutions and cleaning agents.

MAINTENANCE

GENERAL CLEANING

Equipment can be cleaned with a solution of mild detergent and warm water. A variety of surface disinfectants are available for use in dental treatment rooms. Some of these can cause discoloration of painted, plated or anodized surfaces with repeated use. This can be minimized by careful adherence to the disinfectant manufacturer's instructions and by frequent washing with soap and water.



CAUTION: Do not use powdered cleansers, scouring pads or abrasive scrubbers on any of the painted, plastic or metal surfaces of this dental delivery system. To remove dried-on material, use a soft bristled brush and a solution of mild detergent.

ASSISTANT'S VACUUM INSTRUMENTS

AFTER EACH PATIENT: Draw clear water through each valve, while opening and closing it several times. Leave the valve open for several seconds to allow all of the water to clear the hoses. The HVE and Saliva Ejector tips should always be replaced with sterile ones before each patient.

END OF EACH DAY: We recommend that you draw a vacuum system sanitizing solution through each valve, while opening and closing it. EcoVac is an effective vacuum system cleaner that is non-toxic and environmentally safe.

HANDPIECE FLUSH - DAILY MAINTENANCE

The dental delivery system is equipped with a handpiece flush system that allows you to periodically flush fresh water through the handpiece tubings. The need for this is caused by the low flow of water through the tubings during normal use, which can lead to stagnation and the potential growth of "biofilm" contamination.

It is recommended that you flush the tubings at the beginning and end of each day. This may be done with or without the handpieces installed, but having the handpieces on the tubings will restrict flow, so a longer flush time will be required. All of the tubings are flushed simultaneously. Hold them together and direct them into a basin, sink or cuspidor to catch the water. Flip and hold the flush toggle.

Allow adequate time for fresh water to make its way through the entire system and displace all standing water. The American Dental Association and the Centers for Disease Control can provide additional recommendations regarding this procedure, including information on frequency and duration of flushing and the use of antibacterial solutions in the self-contained water system.



WARNING: In order to mitigate the risk of cross-contamination between patients, disinfection and sterilization of handpieces **must occur after each dental procedure**. Refer to the handpiece manufacturer's instructions and recommendations for sterilization or disinfection procedure.

MAINTENANCE

DENTAL DELIVERY SYSTEM - WEEKLY MAINTENANCE

A cleaning procedure should be performed at least once a week, preferably at the start of the week before treating patients. If the dental delivery system is to be stored for any length of time, perform a weekly maintenance routine immediately before and after storage.

Purge the dental delivery system with air.

1. Flush the system with disinfectant solution:
 - a. Turn the dental delivery system Master switch to the off position. Empty the water bottle, replacing the water with cleaning solution.
 - b. Hold the handpiece tubing and syringe over the cuspidor or other suitable container. Turn the dental delivery system on, wait a few moments, then operate the flush toggle, syringe and foot control until a continuous stream of cleaning solution is running through the system.
2. Allow the disinfectant to remain in the dental delivery system for 10 to 20 minutes, then flush the system again until all the cleaning solution is used up.
3. Purge the dental delivery system with air:
 - a. Hold the handpiece tubing and syringe over a container. Turn the Master Switch to the On position, wait a few moments, then operate the flush toggle, syringe and foot control until all cleaning solution is purged from the system.
 - b. Turn the dental delivery system Master Switch to the Off position. (If the dental delivery system will be stored, stop here.)
4. Fill with clean water:
 - a. With the dental delivery system Master Switch turned to the Off position, remove the empty disinfectant bottle. Replace with clean bottle and clean water.
 - b. Hold the handpiece tubing over a suitable container. Turn the dental delivery system on, wait a few moments, then operate the flush toggle until a continuous stream of water is flowing through the system. Replace handpieces and do the same with the syringe. The dental delivery system is now ready for use.

HANDPIECE OIL COLLECTOR

Replace the 2" x 2" gauze pads with clean pads in the handpiece oil collector at least every 90 days, or more often if handpieces are oiled frequently. Remove the oil collector by squeezing the sides and pulling downward.

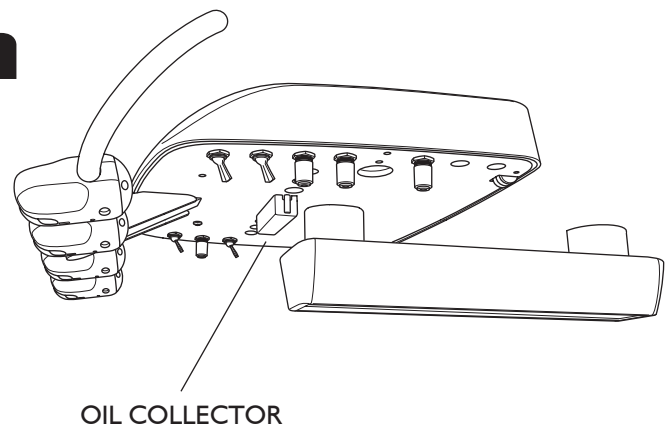

MAINTENANCE

SOLIDS COLLECTOR

Turn off the vacuum pump. Remove the solids collector cap and lift out and dispose of the screen. If you find an excessive amount of material in the screen, more frequent cleaning is necessary.

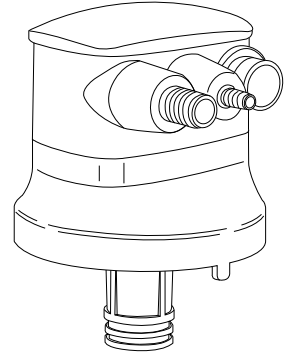

SELF-CONTAINED WATER SYSTEM

The self-contained water system is designed to optimize the quality of water being delivered to the handpieces and syringes. The self-contained water system has three functions:

1. The system may be filled with filtered or sterile water for patient use.
2. The system may be filled with disinfectant for flushing the syringe and handpiece tubing.
3. The dental delivery system can be purged with air to inhibit the growth of biofilm.

In order to maintain a truly aseptic water system, daily and weekly cleaning procedures must be performed in a consistent, regular manner. Failure to do so could result in contaminated water lines and a lower water quality than what is acceptable for patient use. Follow a daily and weekly maintenance routine for proper cleaning of the tubing with the clean water system.

DISINFECTING THE BOTTLE



CAUTION: Disinfect new water bottle prior to first use.

Fill bottle with the 100 ml disinfectant solution, shake vigorously and let it settle for 10 minutes. Shake again, then rinse twice with water.

It is recommended that 100 ml of disinfectant solution is mixed for each weekly bottle disinfecting procedure. Always use a fresh mixture every week.

The Disinfectant Solution:

- 9 parts (90 ml) Tap water
- 1 part (10 ml) 5.25% Sodium hypochlorite (household bleach)

ELECTROMAGNETIC COMPATIBILITY

DEVICE COMPATIBILITY

ELECTRICAL MEDICAL

Electrical medical devices are subject to special EMC safety measurements and as a result the equipment must be installed according to the installation instruction manual.

PORTABLE ELECTRONIC DEVICES

Portable and mobile high frequency electronic communications equipment may interfere with electronic medical devices.

STATIC SENSITIVE DEVICES

Where labeled this equipment contains static sensitive devices that require special precautions when handling. At a minimum a grounded wrist strap that is connected to a ground stud should be worn to reduce the possibility of damage.

ACCESSORY USE

Using accessory devices not specified by DCI for use with their equipment may result in an increase of electromagnetic emissions and/or a decrease in electromagnetic immunity of the system.

INTERFERENCE FROM OTHER EQUIPMENT

If other equipment is used adjacent to or stacked with the DCI Edge equipment, the system must be observed to verify normal operation.

DCI EDGE EQUIPMENT COMPLIANCE

This equipment has been tested and found to comply with the limits for medical devices in IEC 60601-1-2. These limits are designed to provide reasonable protection against harmful interference in a typical medical installation. In the event of interference, power the devices from separate mains supplies and/or increase the physical distance between devices. Contact Customer Service if you have any questions.

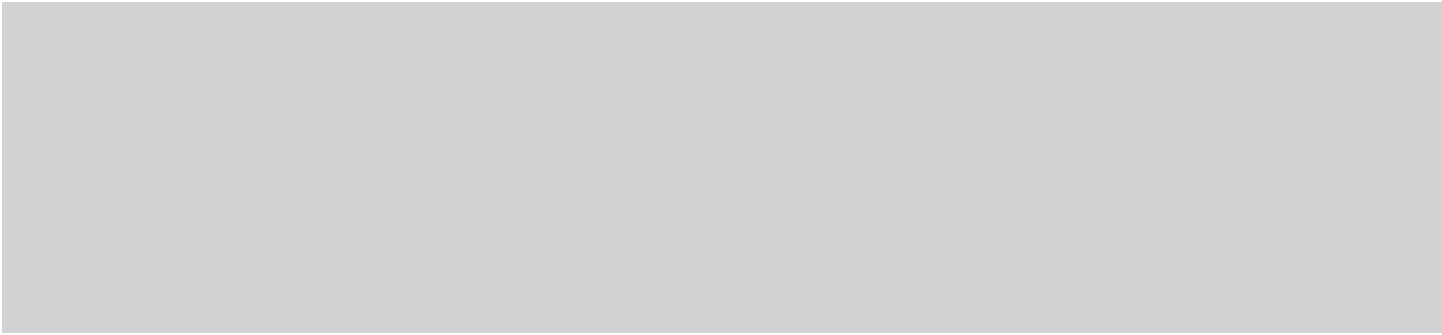

PN 40013, Rev. F, 2024-04-29

www.dcionline.com
800-624-2793



DCI International, LLC
705 S. Springbrook Road Bldg C
Newberg, OR 97132, USA